

# FOREWORD

---

The following instructions provide a general description of the proper procedures which must be considered before starting operations with any of Midland Manufacturing Limited's dump equipment.

Although the information in this manual was current on the date of issue, Midland Manufacturing Limited reserves the right to effect changes as the need occurs without notice or liability.



# MIDLAND MANUFACTURING LIMITED

## TRAILER WARRANTY

Midland Manufacturing Limited (hereafter referred to as "Midland") warrants directly to you, the first retail customer; that each new trailer manufactured by Midland is free from defects in material and workmanship; provided that the trailer is being properly maintained; and that the trailer is being used in its normal intended service free from accident or collision.

**Normal service** means usage in the manner and for the purpose for which such trailer is generally manufactured, purchased and utilized; including the loading, unloading, and carriage of uniformly distributed legal loads of non corrosive cargo, in a manner which does not subject this vehicle to strains, impacts, and dump cycles greater than normally imposed by lawful use over properly maintained public roads, with gross vehicle weight, gross axle weights and concentrated loads not exceeding the labeled gross vehicle weight, gross axle weight and concentrated load ratings (also see "Usage Qualifier" note below).

**The warranty shall (unless otherwise specified) be for the following period following the date of delivery:**

- Structural components (manufactured by Midland) – five years (conditional / prorated)\*
- Non-structural components (manufactured by Midland) – one year
- Midland does not warrant parts and accessories supplied by others. Midland assigns to the customer any warranties provided in favor of Midland with respect to any such parts and accessories; which may be legally assigned by Midland.

**\* Prorated / Conditional warranty of components manufactured by Midland:**

- Structural components
  - 1<sup>st</sup> & 2<sup>nd</sup> year - 100% of repair.
  - 3<sup>rd</sup> year - 75% of repair.
  - 4<sup>th</sup> year - 50% of repair.
  - 5<sup>th</sup> year - 25% of repair.
- Non-structural components
  - One year - 100% parts and labor.
- Usage (years) Qualifier:

Midland's warranty may be modified; at Midland's discretion, if said trailer(s) is subjected to exceptionally heavy use; i.e.: Trailer(s) running 24 hours/day, 7 days a week, or some similar scenario. Thus, for example, for every year in use; the trailer(s) is considered to be two (2) or more "usage" years old.

**Midland's warranty will not cover any repairs done without prior discussion; quotation; and express written approval by Midland**

Midland's warranty coverage does not include:

- freight (of parts, components, or the trailer)
- downtime (loss of income)
- other incidental or consequential damages

## **Midland warranty does not cover:**

- Parts that are not defective but which may wear out and have to be replaced; including but not limited to seals, lights, paint, suspension components, brake system components, brake linings, brake drums, bushings (suspension, joints, hinges, and knuckles), tires, wood pieces and the like.
- Alignments or adjustments which are normal maintenance items; not caused by a defect in any components or in the trailer.
- Any trailer or component of a trailer that has been altered (other than by Midland) in any way so as in the judgement of Midland; to affect its operation or reliability, or which has been subject to misuse, neglect or accident.

## **Warranty claims:**

ON ANY REPAIRS UNDER WARRANTY, MIDLAND MUST BE CONTACTED AND OUR APPROVAL RECEIVED IN THE FORM OF A WARRANTY PURCHASE ORDER BEFORE ANY WORK IS DONE.

THE PURCHASER CLAIMING UNDER THIS WARRANTY SHALL SUBMIT A WARRANTY CLAIM IN THE PRESCRIBED FORM TO MIDLAND OR AN AUTHORIZED DEALER FOR INSPECTION BY AN AUTHORIZED COMPANY REPRESENTATIVE.

- 1) We will not accept warranty bills under any circumstances that have not received our prior authorization (including a warranty authorization number); based on a written quotation for the required repair work.
- 2) We are to supply all warranty parts unless agreed otherwise.
- 3) Any invoices covering warranty parts and / or labor that we consider excessive will be paid on the basis of our cost of such parts and / or labor as if the work had been done at our factory.
- 4) No warranty on parts will be paid for until the faulty parts have been returned prepaid, for our inspection, unless agreed otherwise.  
Midland will not be responsible for freight for returned parts except by prior arrangement and written authorization.
- 5) All invoices submitted, requesting warranty, must show the number of hours of labor and the rate being charged.
- 6) Midland must receive notice of a defect immediately after such defect is discovered and at the request of Midland or an authorized agent return the trailer to Midland or an authorized agent or other agreed upon location within 20 days after the trailer return is requested. **Note:** Warranty consideration may be influenced by "when a defect ought to have been discovered under normal circumstances"; in cases where the defect notification is not made in a timely manner.
- 7) Transportation expenses to and from a repair facility are the responsibility of the trailer owner.

## **WARRANTY DISCLAIMER AND LIMITATIONS OF LIABILITY:**

Except for the above warranty, Midland makes no other express warranties and HEREBY EXCLUDES ANY IMPLIED WARRANTY OF MERCHANTABILITY OR FITNESS FOR PARTICULAR PURPOSE.

IT IS AGREED THAT MIDLAND SHALL NOT BE LIABLE FOR INCIDENTAL OR CONSEQUENTIAL DAMAGES RESULTING FROM ANY BREACH OF WARRANTY including, but not limited to, loss of income, damage to vehicle, attachments, trucks or cargo, towing expenses, or injury to or death of persons.

No person is authorized to give any warranties or to assume any other liability on Midland's behalf unless made and assumed in writing by Midland and signed by an officer of Midland.

### **TIME LIMIT ON COMMENCING LEGAL ACTION:**

While Midland undertakes to make reasonable efforts to resolve every warranty claim, if Midland does not accept as valid all or any part of a particular claim, then Midland will only be responsible under this warranty for such claim if it is enforced by legal action commenced within one year from the date that the breach of warranty occurred.

### **WARRANTY TRANSFER:**

Warranty transfers to a second owner will be recognized provided:

- the said transfer takes place in the first twelve (12) months of service
- the said trailer is fully inspected and approved by Midland by way of a personal inspection by an authorized Midland agent
- a new warranty form is filled out and sent to Midland Manufacturing Limited immediately upon close of the transaction. (New Equipment Warranty forms are available from Midland).
- the second warranty form must be returned to Midland showing name of original purchaser and date the trailer was put into service as well as the date and name of the new owner. Any and all warranty periods are begun on the date of sale of the new trailer to the original retail customer.

### **OPERATORS MANUAL:**

The purchaser acknowledges having received training in the safe operation of the trailer unit and further acknowledges that Midland does not assume any liability resulting from the operation of the trailer unit in any manner other than described in the operator's manual supplied at the time of purchase.

**THIS AGREEMENT IS NOT VALID UNLESS A SIGNED COPY OF THE WARRANTY REGISTRATION FORM IS RECEIVED BY MIDLAND WITH 15 DAYS OF DATE OF DELIVERY; TO THE FIRST RETAIL CUSTOMER.**

**Midland Manufacturing Limited**  
Box 249  
Rosenort, Manitoba R0G 1W0



# COMPLIANCE PLATE LOCATION

The trailer compliance plate is mounted where indicated on the trailer, verifying compliance with all applicable Canadian and United States Motor Vehicle Safety Standards and discloses the Gross Vehicle Weight Rating (GVWR) and Gross Axle Weight Rating (GAWR). This plate also has the trailer Serial Number recorded and the date of manufacture.

- V.I.N.**  
Vehicle Identification Number.
- GROSS AXLE WEIGHT RATING (GAWR)**  
Gross axle weight rating is the "rated capacity at the tire-ground interface" and is to reflect the "weakest link" in the entire suspension system, whether it be springs, axles, wheels, rims or tires.
- GROSS VEHICLE WEIGHT RATING (GVWR)**  
The GVWR for semi-trailers is the sum of the trailer tare weight, and that uniformly distributed payload which will result in a suspension load at the tire-ground interface equal to the sum of the trailer's gross axle weight rating (GAWR) with a limitation imposed by practical or structural considerations.

## CANADA

|   |                      |  |             |   |
|---|----------------------|--|-------------|---|
| MANUFACTURED BY / FABRIQUE PAR          |                      | BOX 249<br>ROSENORT, MANITOBA<br>CANADA<br>R0G 1W0<br>PHONE: 204-746-2348<br>www.midlandtrailers.com |             |  |
| <b>Midland</b><br>MANUFACTURING LIMITED |                      |  |             |   |
| GVWR/<br>PNBV                           | <input type="text"/> | KGS.   | DATE        | <input type="text"/>  |
| VIN<br>NIV                              | <input type="text"/> |  |             |   |
| GAWR/PNBE                               | KGS.                 | TIRES/PNEU   | RIM/JANTE   | COLD INFL. PRESS./<br>PRESS. DE GONFL. A FROID<br>PSI/LPC KPA                       |
| FRONT AXLE                              | 10,000               | 11R 22.5 (G)   | 8.25 X 22.5 | 690 KPA   |
| SECOND AXLE                             | 10,000               | 11R 22.5 (G)   | 8.25 X 22.5 | 690 KPA   |
| REAR AXLE                               | 10,000               | 11R 22.5 (G)   | 8.25 X 22.5 | 690 KPA   |
| TYPE: TRA/REM<br>PT# 1812391            | MODEL                | <input type="text"/>   |             |   |

## U.S.

|  |                      |   |                           |                            |
|--|----------------------|---|---------------------------|----------------------------|
| MANUFACTURED BY  |                      | BOX 249<br>ROSENORT, MANITOBA<br>CANADA<br>R0G 1W0<br>PHONE: (204) 746-2348 |                           |                            |
| <b>Midland</b><br>MANUFACTURING LIMITED  |                      |   |                           |                            |
| GVWR   | <input type="text"/> | LBS.  | DATE <input type="text"/> |                            |
| VIN  | <input type="text"/> |   |                           |                            |
| GAWR   | LBS.                 | TIRES   | RIMS                      | COLD INFLATION<br>PRESSURE |
| FRONT AXLE   | 20,000               | 11R 22.5 / 24.5   | 8.25 X 22.5 / 24.5        | 100PSI                     |
| SECOND AXLE  | 20,000               | 11R 22.5 / 24.5   | 8.25 X 22.5 / 24.5        | 100PSI                     |
| REAR AXLE  | 20,000               | 11R 22.5 / 24.5   | 8.25 X 22.5 / 24.5        | 100PSI                     |
| THIS VEHICLE CONFORMS TO ALL APPLICABLE U.S. FEDERAL MOTOR VEHICLE<br>SAFETY STANDARDS IN EFFECT ON THE DATE OF MANUFACTURE SHOWN ABOVE. |                      |   |                           |                            |
| TYPE: TRAILER<br>PT# 1812352   | MODEL                | <input type="text"/>  |                           |                            |

# V.I.N. PLATE LOCATION

Always give your dealer the V.I.N. (Vehicle Identification Number) of your Midland Bottom Dump Gravel Trailer unit when ordering parts or requesting service or other information.

The plate is located where indicated. Please mark the number in the space provided for easy reference. Also obtain and mark down the Model Number, Production Year and other pertinent information of your Trailer unit in the spaces provided.



Registration Holder

**SERIAL NUMBER LOCATION**

V.I.N. Number \_\_\_\_\_

Model Number \_\_\_\_\_

Length \_\_\_\_\_

Suspension \_\_\_\_\_

Axles \_\_\_\_\_

Wheels \_\_\_\_\_

Tires \_\_\_\_\_

Date Purchased \_\_\_\_\_

Dealer Purchased From \_\_\_\_\_

Address \_\_\_\_\_

\_\_\_\_\_



# TABLE OF CONTENTS

| SECTION  | DESCRIPTION                                     | PAGE      |
|----------|---|-----------|
| <b>1</b> | <b>Introduction .....</b>                       | <b>1</b>  |
| <b>2</b> | <b>Safety .....</b>                             | <b>2</b>  |
| 2.1      | General Safety.....                             | 3         |
| 2.2      | Operating Safety .....                          | 4         |
| 2.3      | Maintenance Safety .....                        | 4         |
| 2.4      | Travel Safety.....                              | 5         |
| 2.5      | Loading Safety .....                            | 5         |
| 2.6      | Tire Safety .....                               | 5         |
| 2.7      | Safety Signs .....                              | 5         |
| 2.8      | Air/Gate Safety.....                            | 5         |
| 2.9      | Sign-Off Form .....                             | 6         |
| <b>3</b> | <b>Safety Sign Locations .....</b>              | <b>7</b>  |
| <b>4</b> | <b>Operation Guidelines .....</b>               | <b>11</b> |
| 4.1      | To the New Operator or Owner .....              | 11        |
| 4.2      | Terminology.....                                | 12        |
| 4.3      | Break-In.....                                   | 13        |
| 4.4      | Controls.....                                   | 15        |
| 4.5      | Pre-Operation Vehicle Inspection Procedure..... | 20        |
| 4.6      | Hooking Up/Unhooking .....                      | 23        |
| 4.6.1    | Hooking Up.....                                 | 23        |
| 4.6.2    | Unhooking.....                                  | 25        |
| 4.7      | Discharge Gates.....                            | 26        |
| 4.7.1    | Clam Shell Discharge Gate .....                 | 26        |
| 4.7.2    | Close Under Load (CUL) Gates .....              | 27        |
| 4.8      | Air System.....                                 | 28        |
| 4.8.1    | Filter and Oiler.....                           | 28        |
| 4.8.2    | Tanks .....                                     | 29        |
| 4.8.3    | Cylinders .....                                 | 30        |
| 4.9      | Loading/Unloading.....                          | 31        |
| 4.10     | Transporting .....                              | 33        |
| 4.10.1   | Operating Instructions.....                     | 33        |
| 4.10.2   | Braking Guidelines.....                         | 34        |
| 4.10.3   | Tires .....                                     | 35        |
| 4.11     | Optional Equipment .....                        | 36        |

# TABLE OF CONTENTS

| SECTION  | DESCRIPTION                                     | PAGE      |
|----------|---|-----------|
| <b>5</b> | <b>Service and Maintenance</b> .....            | <b>39</b> |
| 5.1      | Service .....                                   | 39        |
| 5.1.1    | Fluids and Lubricants.....                      | 39        |
| 5.1.2    | Greasing.....                                   | 39        |
| 5.1.3    | Servicing Intervals.....                        | 40        |
| 5.1.4    | Service Record Summary (Lubrication) .....      | 52        |
| 5.2      | Periodic Maintenance and Adjustments .....      | 53        |
| 5.2.1    | Torque Specification Summary .....              | 53        |
| 5.2.2    | Kingpin and Oscillating Fifth Wheel Plate ..... | 55        |
| 5.2.3    | Fifth Wheel .....                               | 56        |
| 5.2.4    | Axle Alignment .....                            | 57        |
| 5.2.5    | Wheel Hubs/Bearings .....                       | 59        |
| 5.2.6    | Wheels .....                                    | 63        |
| 5.2.7    | Tires.....                                      | 65        |
| 5.2.8    | Brakes .....                                    | 67        |
| 5.2.9    | Slack Adjusters .....                           | 71        |
| 5.2.10   | Trailer ABS.....                                | 77        |
| 5.2.11   | Air Chamber/Spring Brake .....                  | 78        |
| 5.2.12   | Suspension System .....                         | 79        |
| 5.2.12.1 | Air Ride Suspension.....                        | 79        |
| 5.2.12.2 | Mechanical Suspension .....                     | 83        |
| 5.2.13   | Air System.....                                 | 85        |
| 5.2.13.1 | Air System Inspection .....                     | 85        |
| 5.2.13.2 | Air System Function.....                        | 85        |
| 5.2.14   | Electrical System.....                          | 86        |
| 5.2.15   | Discharge Gate .....                            | 87        |
| 5.2.16   | Oiler.....                                      | 88        |
| <b>6</b> | <b>Trouble Shooting</b> .....                   | <b>89</b> |
| <b>7</b> | <b>Specifications</b> .....                     | <b>97</b> |
| 7.1      | Bolt Torque.....                                | 97        |
| <b>8</b> | <b>Index</b> .....                              | <b>98</b> |

# 1 INTRODUCTION

Midland appreciates having you for our customer and trust this unit will give you many years of trouble-free use. We are pleased to have you join a growing number of operators pulling Midland trailers.

We take pride in building products to meet the demands of a discriminating buyer in a variety of industries; transportation industry, mining, oil field, paving, aggregate hauling, and excavation. We have sought to anticipate your needs with respect to safety, convenience, design and engineering of your unit. Midland provides information and service support to its customers through its distributor and dealer network. Contact them should you need assistance.

Safe, efficient and trouble free operation of your Midland Trailer requires that you and anyone else who will be operating or maintaining the Trailer, read this manual carefully and understand the Safety, Operation, Maintenance and Trouble Shooting information contained within the Operator's Manual. Failure to read and follow instructions in the manual could lead to costly repairs; and even more importantly could lead to serious injuries and possibly death.



This manual covers these Bottom Dump Gravel Trailer models built by Midland:

1. Tandem Axle - Close Under Load Gates (CUL)
2. Triaxle-Close Under Load Gates (CUL)
3. Tandem Axle Clam
4. Triaxle Clam
5. Super B Clam and CUL Trains

Although some of the diagrams and pictures may not apply to all trailers, we have tried to show details of common adjustments and features that are on standard production units.

Use the Table of Contents or Index as a guide in locating the specific information applicable to your Trailer. Keep this manual handy for frequent reference and to pass on to new operators or owners.

**OPERATOR ORIENTATION** - The directions left and right as mentioned throughout this manual, are taken as if the operator was standing behind the trailer facing forward.

## 2 SAFETY

### SAFETY ALERT SYMBOL

This Safety Alert symbol means **ATTENTION! BECOME ALERT! YOUR SAFETY IS INVOLVED!**



The Safety Alert symbol identifies important safety messages on the Midland Trailer and in the manual. When you see this symbol, be alert to the possibility of personal injury or death. Follow the instructions in the safety message.

Why is SAFETY important to you?

#### 3 Big Reasons

**Accidents Disable and Kill**  
**Accidents Cost**  
**Accidents Can Be Avoided**

#### SIGNAL WORDS:

Note the use of the signal words **DANGER**, **WARNING** and **CAUTION** with the safety messages. The appropriate signal word for each message has been selected using the following guide-lines:

**DANGER:** Indicates an imminently hazardous situation that, if not avoided, will result in death or serious injury. This signal word is to be limited to the most extreme situations, typically for machine components that, for functional purposes, cannot be guarded.

**WARNING:** Indicates a potentially hazardous situation that, if not avoided, could result in death or serious injury, and includes hazards that are exposed when guards are removed. It may also be used to alert against unsafe practices.

**CAUTION:** Indicates a potentially hazardous situation that, if not avoided, may result in minor or moderate injury. It may also be used to alert against unsafe practices.

# SAFETY

**YOU are responsible** for the **SAFE** operation and maintenance of your Midland Trailer. **YOU MUST** ensure that you and anyone else who is going to operate, maintain or work around the Trailer be familiar with all the operating and maintenance procedures and related **SAFETY** information contained in this manual.

Remember, **YOU** are the key to safety. Good safety practices not only protect you but also the people around you. Make these practices a working part of your safety program. Be certain that **EVERYONE** operating this equipment is familiar with the recommended procedures and follows all the safety precautions. Remember, most accidents can be prevented. Do not risk injury or death.

- Remember, you are not just a driver; you are expected to be an effective and efficient operator.
- Trailer owners **MUST** give operating instructions to operators or employees **before** allowing them to operate the equipment or doing any maintenance work on the trailer, and at least annually thereafter.
- The most important safety device on this equipment is a **SAFE** operator. It is the operator's responsibility to read and understand **ALL** Safety and Operating instructions in the manual and to follow these. All accidents can be avoided.
- Midland feels that a person who has not read, understood and been trained to follow all operating and safety instructions is not qualified to operate or do any maintenance work on the equipment. An untrained operator exposes himself and bystanders to possible serious injury or death.
- **DO NOT** modify the equipment in any way. Unauthorized modification may impair the function and/or safety of the equipment and affect Trailer life.
- Think SAFETY! Work SAFELY!

## 2.1 GENERAL SAFETY

1. Read and understand the Operators Manual and all safety signs before operating, maintaining or adjusting the Trailer.



2. Only trained competent persons shall operate the Trailer. An untrained operator is not qualified to operate the unit.

3. Have a first-aid kit available for use should the need arise and know how to use it.



4. Do not allow riders on any part of the trailer.

5. Have a fire extinguisher available for use should the need arise and know how to use it.

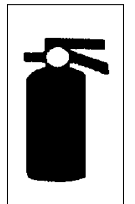

6. Wear appropriate protective gear. This list includes but is not limited to:

- A hard hat
- Protective shoes with slip resistant soles
- Heavy gloves



7. Place all controls in neutral, stop truck engine, set park brake, remove ignition key and wait for all moving parts to stop and all air pressure to be fully exhausted before servicing, adjusting or repairing.
8. Do not drink and drive.

## 2.2 OPERATING SAFETY

1. Read and understand all of the Operator's Manual and all safety signs before operating or adjusting the Midland Trailer.
2. Do not allow riders on any part of the trailer.
3. Drive very carefully when negotiating hilly or uneven terrain.
4. Keep hands, feet, clothing and hair away from all moving parts.
5. Place all controls in neutral, stop the engine, set park brake, remove ignition key and wait for all moving parts to stop and all air pressure to be fully exhausted before servicing, adjusting, repairing or maintaining.
6. Stay away from discharge gates when truck engine is running and/or the air system is pressurized. Keep others away.
7. Use care when manually operating discharge gates. Always know where your operating partner is before moving gates to prevent injury.
8. Disconnect air lines and exhaust air system completely before working on discharge gates or cylinders. Do not enter or reach into trailer until air system is completely exhausted and you know gates cannot close.

**IMPORTANT:** When using gate (open position) locking mechanism; air lines must be disconnected and air system must be completely exhausted after locking mechanism is engaged (pin is installed)

**NOTE:** The locking pin is **NOT** designed to hold the gates in the open position under air pressure

9. Maintain king pin, fifth wheel assembly and all running gear in good condition at all times.
10. Clear the area of all bystanders, especially children, before starting up and operating the tractor and trailer.
11. Make sure that all lights and reflectors that are required by the local highways and transport authorities are in place, clean and can be seen clearly by all overtaking and oncoming traffic.
12. Do not operate unit with spring brakes caged or brakes disabled. Block wheels if unhooked.

13. Before disconnecting the tractor from the trailer unit(s) make sure that the tractor and trailer are on level ground and that the trailer wheels are securely blocked. Lower landing gear and provide extra support if the ground is soft. Do not unhook if trailer is loaded.
14. Do not dump unless the trailer is on firm level surface; with all wheels in contact with that firm level surface
15. Review safety items with all personnel annually or more frequently as necessary.

## 2.3 MAINTENANCE SAFETY

1. Read and understand all the information in the Operator's Manual regarding maintenance, adjusting and servicing the Trailer unit.
2. Place all controls in neutral, stop the truck engine, remove ignition key, set the park brake, and exhaust all air pressure from trailer air system before adjusting, servicing or maintaining any part of the Trailer unit.
3. Follow good shop practices:
  - Keep service area clean and dry.
  - Be sure electrical outlets and tools are properly grounded.
  - Use adequate light for the job at hand.
4. Cage spring brake chamber before disassembling.
5. Block wheels before de-activating brakes.
6. Disconnect air lines and exhaust air system completely before working on discharge gates or cylinders.
7. Maintain fasteners in running gear systems at their specified torque at all times.
8. Establish and maintain a Trailer Preventative Maintenance (TPM) program on your equipment. Some jurisdictions require this program and the maintenance of records on every commercial vehicle on the road for future reference.



## 2.4 TRAVEL SAFETY

1. Read and understand all the information in the operator's manual regarding procedures and safety when operating the Trailer unit in the field or on the road.
2. Make sure all the lights and reflectors that are required by the local highway and transport authorities are in place, are clean and can be seen clearly by all overtaking and oncoming traffic.
3. Drive carefully and defensively at all times and especially when negotiating uneven or hilly terrain.
4. Do not allow riders on any part of the trailer.
5. Make sure you are in compliance with all local regulations regarding transporting on public roads and highways. Consult your local law enforcement agency for further details.

## 2.5 LOADING SAFETY

1. Do not drop load into trailer to prevent damaging sides or bottom.
2. Use common sense when loading material containing large rocks or frozen chunks to prevent damaging gates and hoppers.
3. Do not exceed total load carrying specifications for trailer.

## 2.6 TIRE SAFETY

1. Failure to follow proper procedures when mounting a tire on a wheel or rim can produce an explosion which may result in serious injury or death.
2. Do not attempt to mount a tire unless you have the proper equipment and experience to do the job.
3. Have a qualified tire dealer or repair service perform required tire maintenance.

## 2.7 SAFETY SIGNS

1. Keep safety signs clean and legible at all times.
2. Replace safety signs that are missing or have become illegible.
3. Replaced parts that displayed a safety sign should also display the current sign.
4. Safety signs damaged or removed, available at no extra charge. Contact your dealer or factory.

### How to Install Safety Signs:

- Be sure that the installation area is clean and dry.
- Be sure temperature is above 50°F (10°C).
- Decide on the exact position before you remove the backing paper.
- Remove the smallest portion of the split backing paper.
- Align the sign over the specified area and carefully press the small portion with the exposed sticky backing in place.
- Slowly peel back the remaining paper and carefully smooth the remaining portion of the sign in place.
- Small air pockets can be pierced with a pin and smoothed out using the piece of sign backing paper.

## 2.8 AIR/GATE SAFETY

1. Make sure that all air system related components are checked regularly and maintained in good condition.
2. Replace any worn, cut, flattened or crimped hoses on air lines and fittings.
3. Exhaust air system completely (and remove air supply hose to trailer) before commencing on any repairs/inspections of cylinders or gates.
4. Before re-energizing the air system on the trailer, you must do a walk around inspection to ensure that no one is in the trailer and no one is in the vicinity of the gates and cylinders.

## 2.9 SIGN-OFF FORM

Midland follows the general Safety Standards specified by the Society of Automotive Engineers (SAE) and the Occupational Safety and Health Administration (OSHA). Anyone who will be operating and/or maintaining the Midland Trailer must read and clearly understand ALL Safety, Operating and Maintenance information presented in this manual.

Do not operate or allow anyone else to operate this equipment until such information has been reviewed and understood. Annually, or more often as needed, review this information with all personnel.

Make these periodic reviews of SAFETY and OPERATION a standard practice for all of your equipment.

A sign-off sheet is provided for your record keeping to show that all personnel who will be working with the equipment have read and understand the information in the Operator's Manual and have been instructed in the safe operation of the equipment.

### SIGN-OFF FORM

| DATE | EMPLOYEE'S SIGNATURE | EMPLOYER'S SIGNATURE |
|------|----------------------|----------------------|
|      |                      |                      |
|      |                      |                      |
|      |                      |                      |
|      |                      |                      |
|      |                      |                      |
|      |                      |                      |
|      |                      |                      |
|      |                      |                      |
|      |                      |                      |
|      |                      |                      |
|      |                      |                      |
|      |                      |                      |
|      |                      |                      |
|      |                      |                      |
|      |                      |                      |
|      |                      |                      |
|      |                      |                      |
|      |                      |                      |
|      |                      |                      |
|      |                      |                      |
|      |                      |                      |
|      |                      |                      |



# 3 SAFETY SIGN LOCATIONS

The types of safety signs and locations on the equipment are shown in the illustration below. Good safety requires that you familiarize yourself with the various safety signs, the type of warning and the area, or particular function related to that area, that requires your SAFETY AWARENESS.

- Think SAFETY! Work SAFELY!

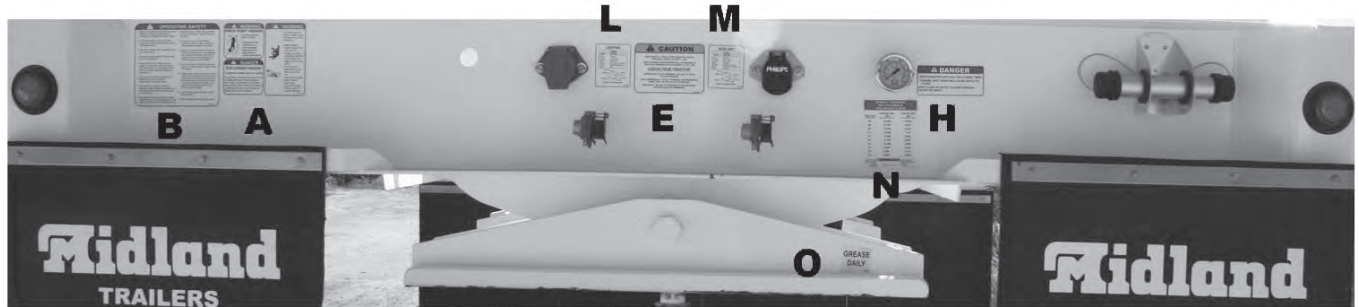

**A**

**WARNING**

**PINCH POINT HAZARD**

To prevent serious injury or death:

- Exhaust air from system prior to servicing gates.
- Stay away from gates when air system pressurized.

**WARNING**

To prevent serious injury or death, keep components in good condition:

- Match wheels, studs, brake drums and capnuts.
- Retorque wheel nuts after initial 50 to 100 miles and again at 200 to 300 miles.
- Check kingpin attachment when attaching to tow unit.
- Clean and lubricate upper coupler.
- Check axle alignment during break-in and at regular intervals.

**DANGER**

**EXPLOSION HAZARD**

To prevent serious injury or death:

Cage brake chamber before servicing or disassembling. If spring brakes are caged, deactivated or removed, this vehicle could have no emergency or parking brakes. Do not transport. Block wheels when parked.

1812340

**L**

**LIGHTING**

| COLOR  | FUNCTION              |
|--------|-----------------------|
| WHITE  | GROUND                |
| YELLOW | LEFT TURN             |
| GREEN  | RIGHT TURN            |
| RED    | STOP/ABS              |
| BROWN  | TAIL/CLEARANCE/MARKER |
| BLACK  | CLEARANCE/MARKER      |
| BLUE   | ABS                   |

7 WIRE PLUG CONFIGURATION  
1812400

**M**

**AUXILIARY**

| COLOR  | FUNCTION                 |
|--------|--------------------------|
| WHITE  | GROUND                   |
| YELLOW | GATE TRIP                |
| GREEN  | AUXILIARY/AIR TRAP       |
| RED    | AUXILIARY/HIGH LIFT GATE |
| BROWN  | LIFT AXLE                |
| BLACK  | DUMP VALVE               |
| BLUE   | AUXILIARY                |

7 WIRE PLUG CONFIGURATION  
1812401

**B**

**OPERATING SAFETY**

1. Read and understand all the Operator's Manual and all safety signs before operating or adjusting the Midland Trailer.
2. Do not allow riders on any part of the trailer.
3. Drive very carefully when negotiating hilly or uneven terrain.
4. Keep hands, feet, clothing and hair away from all moving parts.
5. Place all controls in neutral, stop the engine, set park brake, remove ignition key and wait for all moving parts to stop before servicing, adjusting, repairing or maintaining.
6. Stay away from discharge gates when engine is running and the air system is pressurized. Keep others away.
7. Use care when manually operating discharge gates. Always know where your operating partner is before moving gates to prevent injury.
8. Disconnect air lines and exhaust system before working on discharge gates. Do not enter or reach into trailer unless you know that the air system is completely exhausted and the gates cannot close.
9. Maintain king pin, fifth wheel assembly and all running gear in good condition at all times.
10. Clear the area of all bystanders, especially children, before starting up and operating the tractor and trailer.
11. Make sure that all lights and reflectors that are required by the local highways and transport authorities are in place, clean and can be seen clearly by all overtaking and oncoming traffic.
12. Do not operate unit with spring brakes caged or brakes disabled. Block wheels if unhooked.
13. Before disconnecting the tractor from the trailer unit(s) make sure that the tractor and trailer are on level ground and that the trailer wheels are securely blocked. Lower landing gear and provide extra support if the ground is soft. Do not unhook if trailer is loaded.
14. Do not dump unless vehicle is on firm level surface.
15. Review safety items with all personnel annually.

**N**

**INTRAAAX / VANTRAAAX  
PSI / LOAD SCALE  
FOR 23K AXLE LOADS**

| Req'd psi | Load per axle (lbs) | Load per axle (kg) |
|-----------|---------------------|--------------------|
| 95        | 23,000              | 10,433             |
| 86        | 21,000              | 9,525              |
| 80        | 19,000              | 8,618              |
| 71        | 17,000              | 7,711              |
| 61        | 15,000              | 6,804              |
| 52        | 13,000              | 5,897              |
| 43        | 11,000              | 4,990              |
| 34        | 9,000               | 4,082              |
| 25        | 7,000               | 3,175              |
| 16        | 5,000               | 2,268              |

**HENDRICKSON**

**O**

**RIDEWELL SUSPENSIONS RAR-260**

| ITEM                    | SIZE      | TORQUE                    |
|-------------------------|-----------|---------------------------|
| Pivot Bolt (Shear-Type) | 7/8"-9NC  | See Below                 |
| Pivot Nut (Lock Nut)    |           |                           |
| Shock Bolt/Nut          | 3/4"-10NC | 200-230 ft-lb 271-312 N-m |
| Air Spring Nut - Upper  | 3/4"-16NF | 45-50 ft-lb 61-68 N-m     |
| Air Spring Nut - Lower  | 1/2"-13NC | 45-50 ft-lb 61-68 N-m     |
| Air Spring Bolt - Lower | 1/2"-13NC | 20-25 ft-lb 27-34 N-m     |

Tighten pivot bolt using a 1" drive impact wrench and RW #6100054 E-20 Torx® socket (or equivalent) until Torx® head shears off. Suspension fasteners to be re-torqued initially at 6,000 miles and at 50,000 mile increments thereafter. Do not re-torque pivot fasteners. See service manual for details.  
Ridewell Suspensions • Springfield, MO, USA • 800.641.4122 • www.ridewellcorp.com

**O**

**GREASE  
DAILY**

1812304

REMEMBER - If safety signs have been damaged, removed, become illegible or parts replaced without signs, new signs must be applied. New signs are available from your authorized dealer.

The types of safety signs and locations on the equipment are shown in the illustration below. Good safety requires that you familiarize yourself with the various safety signs, the type of warning and the area, or particular function related to that area, that requires your SAFETY AWARENESS.

- Think SAFETY! Work SAFELY!

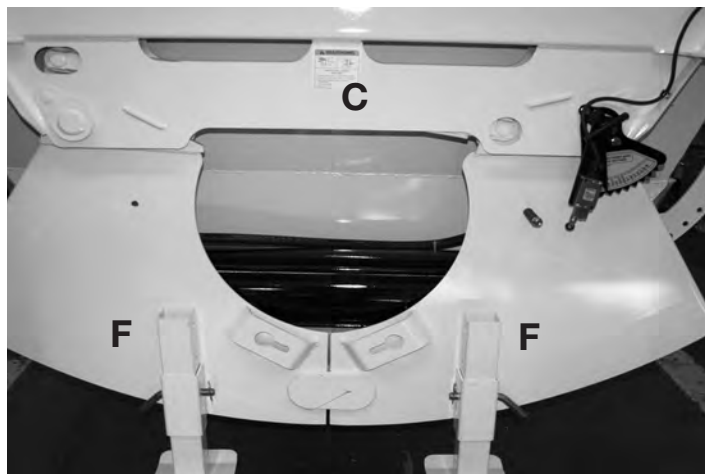

This decal appears 8 times on TC and MC trailers, and 6 times on MX trailers.

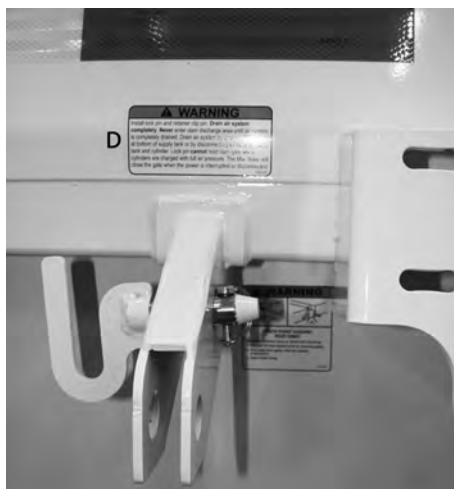

This decal appears 2 times on TC and MC trailers.

REMEMBER - If safety signs have been damaged, removed, become illegible or parts replaced without signs, new signs must be applied. New signs are available from your authorized dealer.

The types of safety signs and locations on the equipment are shown in the illustration below. Good safety requires that you familiarize yourself with the various safety signs, the type of warning and the area, or particular function related to that area, that requires your SAFETY AWARENESS.

- Think SAFETY! Work SAFELY!

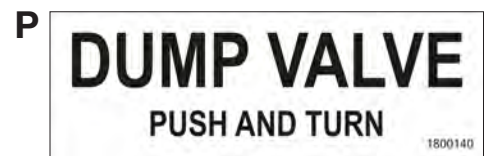
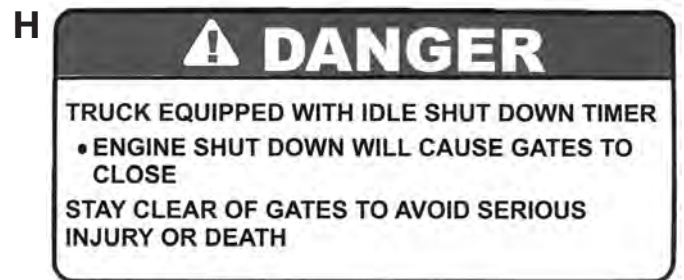
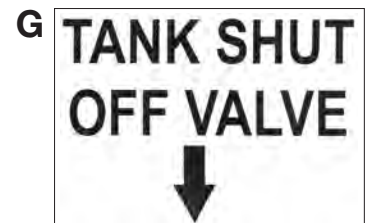
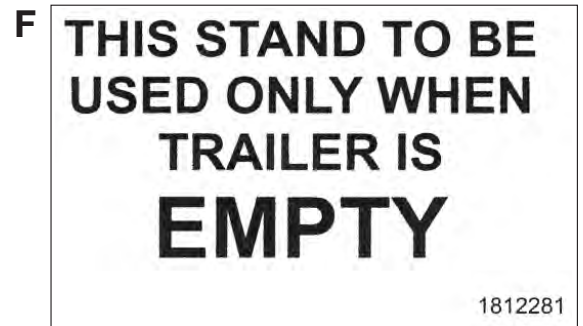
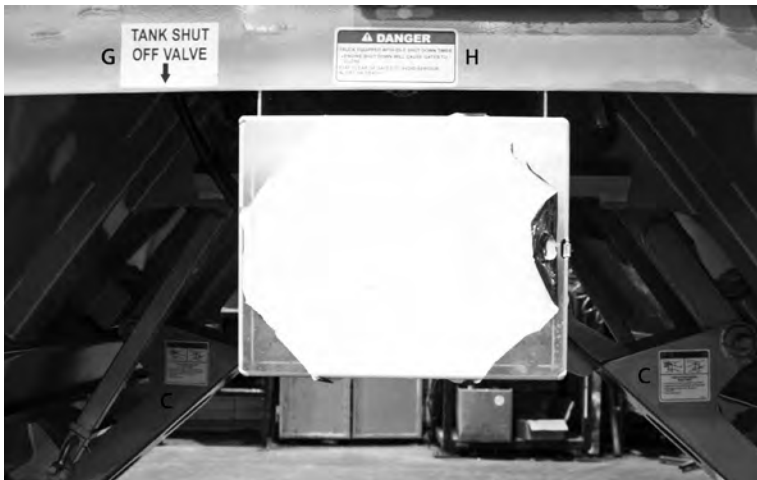

REMEMBER - If safety signs have been damaged, removed, become illegible or parts replaced without signs, new signs must be applied. New signs are available from your authorized dealer.



The types of safety signs and locations on the equipment are shown in the illustration below. Good safety requires that you familiarize yourself with the various safety signs, the type of warning and the area, or particular function related to that area, that requires your SAFETY AWARENESS.

- Think SAFETY! Work SAFELY!

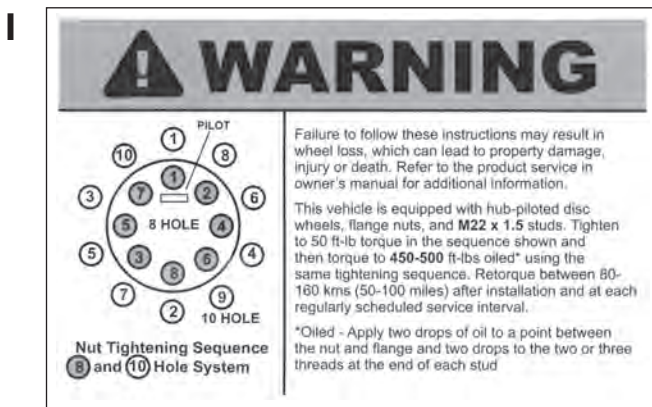

This decal appears 2 times on all bottom dump trailers.



This decal appears 2 times on TC and MC trailers.



**Q**

| RIDEWELL RAR-260        |           |                           |
|-------------------------|-----------|---------------------------|
| ITEM                    | SIZE      | TORQUE                    |
| Pivot Bolt (Shear-Type) | 7/8"-9NC  | See Below                 |
| Pivot Nut (Lock Nut)    |           |                           |
| Shock Bolt/Nut          | 3/4"-10NC | 200-230 ft-lb 271-312 N-m |
| Air Spring Nut - Upper  | 3/4"-16NF | 45-50 ft-lb 61-68 N-m     |
| Air Spring Nut - Lower  | 1/2"-13NC | 45-50 ft-lb 61-68 N-m     |
| Air Spring Bolt - Lower | 1/2"-13NC | 20-25 ft-lb 27-34 N-m     |

Tighten pivot bolt using a 1"-drive impact wrench and RW #6100054 E-20 Torq\* socket (or equivalent) until Torq\* head shears off. Suspension fasteners to be re-torqued initially at 6,000 miles and at 50,000 mile increments thereafter. Do not re-torque pivot fasteners. See service manual for details.

Ridewell Suspensions • Springfield, MO USA • 800.641.4122 • www.ridewellcorp.com

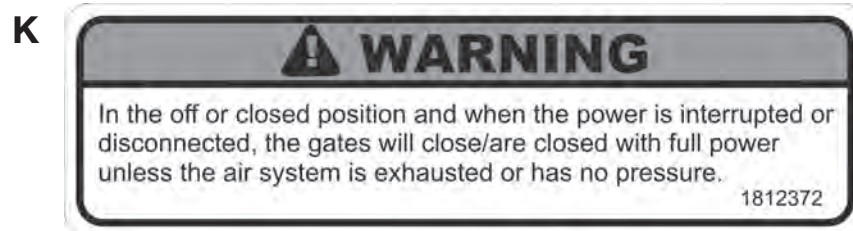

REMEMBER - If safety signs have been damaged, removed, become illegible or parts replaced without signs, new signs must be applied. New signs are available from your authorized dealer.

## 4 OPERATION GUIDELINES

B



### OPERATING SAFETY

1. Read and understand all the Operator's Manual and all safety signs before operating or adjusting the Midland Trailer.
2. Do not allow riders on any part of the trailer.
3. Drive very carefully when negotiating hilly or uneven terrain.
4. Keep hands, feet, clothing and hair away from all moving parts.
5. Place all controls in neutral, stop the engine, set park brake, remove ignition key and wait for all moving parts to stop before servicing, adjusting, repairing or maintaining.
6. Stay away from discharge gates when engine is running and the air system is pressurized. Keep others away.
7. Use care when manually operating discharge gates. Always know where your operating partner is before moving gates to prevent injury.
8. Disconnect air lines and exhaust system before working on discharge gates. Do not enter or reach into trailer unless you know that the air system is completely exhausted and the gates cannot close.
9. Maintain king pin, fifth wheel assembly and all running gear in good condition at all times.
10. Clear the area of all bystanders, especially children, before starting up and operating the tractor and trailer.
11. Make sure that all lights and reflectors that are required by the local highways and transport authorities are in place, clean and can be seen clearly by all overtaking and oncoming traffic.
12. Do not operate unit with spring brakes caged or brakes disabled. Block wheels if unhooked.
13. Before disconnecting the tractor from the trailer unit(s) make sure that the tractor and trailer are on level ground and that the trailer wheels are securely blocked. Lower landing gear and provide extra support if the ground is soft. Do not unhook if trailer is loaded.
14. Do not dump unless vehicle is on firm level surface.
15. Review safety items with all personnel annually.

1812342

### 4.1 TO THE NEW OPERATOR OR OWNER

The Midland Bottom Dump Gravel Trailers combine light weight construction methods and high strength materials to become a safe, reliable and efficient gravel hauling unit. Be sure to familiarize yourself with the Trailer by reading this Operator's Manual and the Safety Alerts before attempting to operate it. With careful use and a good maintenance schedule, the unit will give many years of trouble-free use.

**It is the responsibility of the owner and operator to be familiar with the weight and loading of your trailer or combinations of trailers. Trailer weight and loading vary from jurisdiction to jurisdiction. Be familiar with yours and any that you will be travelling through.**

## 4.2 TERMINOLOGY

The Midland Bottom Dump Trailers are designed with cross or clam shell type discharge gates that are orientated parallel to or at right angles to the direction of travel. Trailers are available in Tandem, Tri-axle and B-Train designs. Some of the standard models and typical features are shown.

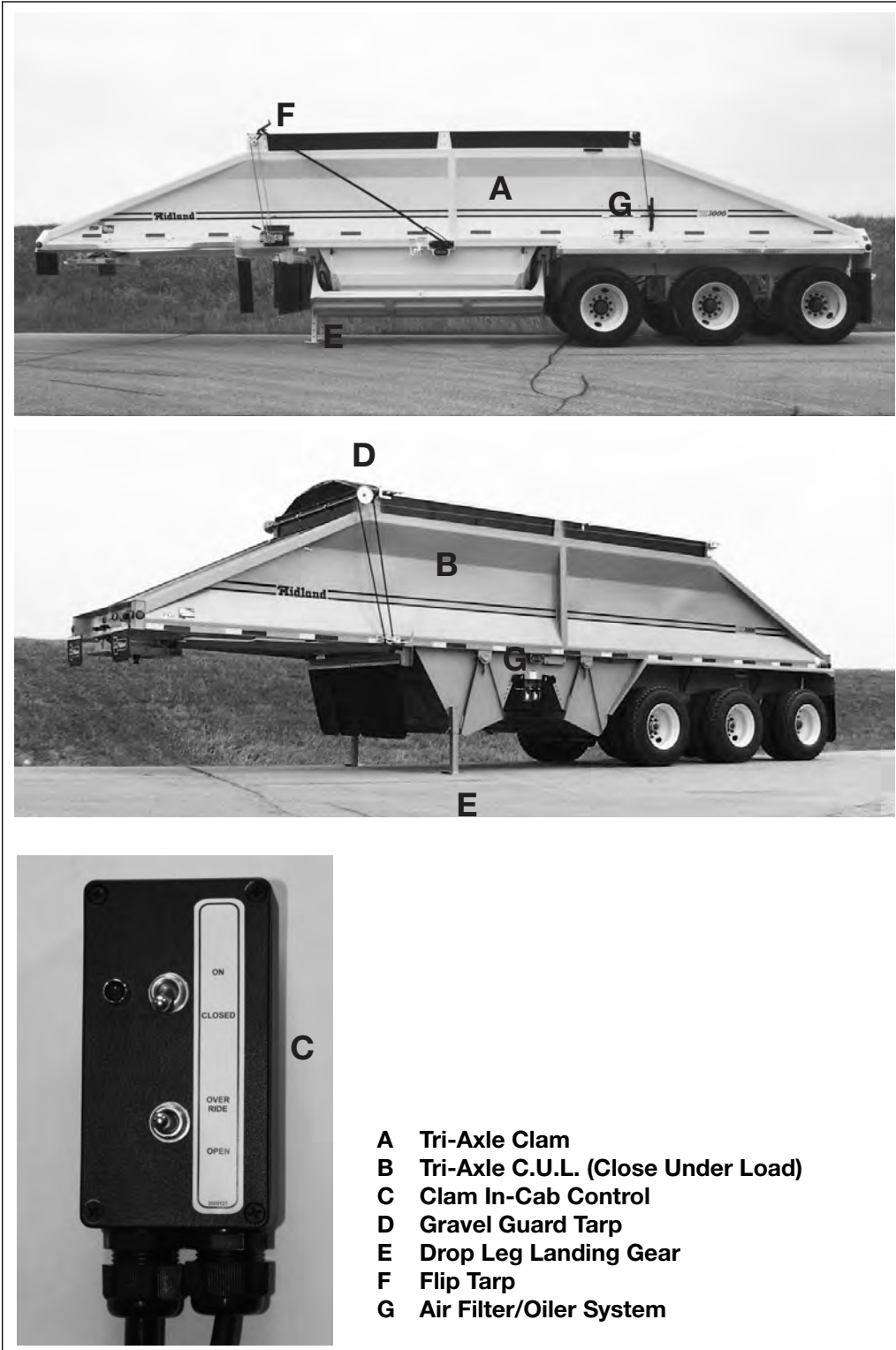

Fig. 1 PRINCIPLE SYSTEMS

## 4.3 BREAK-IN

Break-in is the most important time in a Trailer's life. It is critical that the unit be checked frequently during the first 5000 miles to be sure that all components and systems are properly adjusted and performing as required.

The following inspection schedule is provided as a guide for normal operating conditions. More frequent inspections are recommended in severe or extreme conditions.

### Inspect at:

**50-100 miles, 1-2 hours**

**500 miles, 8-10 hours**

**1500 miles, 25-30 hours**

**5000 miles, 100 hours:**

#### 1. Brakes

It takes a few weeks of operation for the brake shoes to mate with the drum contour and burnish the surface. The operator should check the brakes every day. Check the function and adjustment of the brakes on each axle. All brakes should apply evenly. No shoes should drag on the drum when the brakes are not applied.

#### 2. Tires

Tires are designed to provide maximum life and performance when maintained at their specified inflation pressure. Although the tires are inflated to their specified pressure at the factory, the pressure can change before going into service. Always use an accurate gauge to check the pressure when the tire is cold.

#### 3. Wheels/Rims

Although lug bolts and rim fasteners are always tightened to their specified torque at the factory, it is normal for them to lose some of their torque during the first few miles of operation. After the first 50 miles; retorque lug bolts and rim fasteners. Then go to the retorquing interval defined in the Maintenance section of every 25,000 miles. Keep all fasteners tightened to their specified torque to prevent damaging any components.

Whenever a wheel is removed from an axle, the above retorquing procedure must be followed to be sure that the wheel is secured to the axle. If any component is damaged due to loose fasteners, it will have to be replaced.

#### 4. Axles

Each wheel bearing is assembled at the factory with the required pre-load (refer to Section 5.2.4). This pre-load should be checked to insure proper axle and bearing function. Check the temperature of the hub by hand after 10 to 15 miles (15 to 25 km) during the first trip. A hot hub must have the bearing pre-load reset before continuing.

Jack the axle up and support it on a stand. Turn the wheel by hand. The wheel should turn freely. If it does not, check if the brakes are dragging or if the bearing has too much pre-load. If either of these conditions exist, correct before proceeding.

Move the wheel laterally on the axle shaft. If the wheel wobbles, the bearing has lost its pre-load. Tighten bearing and set pre-load before continuing.

#### 5. Hub Oil Levels:

Oil bath hubs are used on all trailers and are filled at the factory. Check hubs frequently (at least daily) during the first few weeks of operation. Always check when the oil is cold and the trailer is on the level. Use the level mark on the hub face when checking oil level. Replace seals and gaskets if hub has an oil leak. Do not operate without oil in the hub.

## 4.3 BREAK-IN (cont'd)

### 6. Suspension

A suspension system connects the axles to the frame. All fasteners must be maintained at their specified torque to ensure that all clamping and anchoring forces remain intact. If these forces are not maintained, components can shift or move and affect the performance and component life. Refer to Maintenance Section for the list of required torque values for all fasteners in suspension system. Any loosening can lead to component shifting, misalignment and/or twisting. Any of these items can cause erratic handling, broken components or rapid tire wear. Always tighten the nut end of fastener. Specified torque values apply only to nut end torquing.

### 7. Axle Alignment

Axle alignment is properly set at the factory when the unit is new and will remain aligned unless fasteners loosen or components wear or if the tire/axle combination of the trailer take a severe hit; ie: a curb, rock or other obstruction. Use a steel measuring tape to check the alignment. Refer to Maintenance Section for alignment checking procedure. Axles that are out of alignment can cause erratic handling characteristics, broken components and accelerated tire wear.

### 8. Fifth Wheel Assembly Components

The king pin, anchor plate and upper and lower fifth wheel assemblies must be inspected to check for mechanical integrity of all components. All components and systems must be kept in good condition to safely and reliably transmit the accelerating, braking and side loads between the trailer, fifth wheel and towing vehicle.

#### a. King Pin:

Check the king pin for cracks, chips, or whether it is bent. Check that there are no cracks or distortions between the king pin and its anchor plate. If any defects are found, replace the king pin and its anchor

plate before resuming work.

#### b. Oscillating Plate:

Check the rubber bushings and anchor bolt torque on the oscillating plate on a regular basis. Replace the bushings if they are cracked, distorted or loose in their mounts. Retorque the nut on the anchor bolts. Check the plate frame for cracks, bends or distortions. Replace oscillating plate if any of these conditions are found.

#### c. Fifth Wheel Assembly:

The fifth wheel assembly consists of the king pin locking mechanism, surface plate, frame, pivot and anchor system. Check that the king pin locking mechanism locks and unlocks easily and that all moving surfaces are coated with grease. Check that the surface plate is clean and coated with grease.

Check the surface plate, pivot and anchor frame for cracks, bends or distortions. Replace any damaged components. Retorque fasteners to maintain the proper clamping forces on all components. Loose fasteners can cause components to move or bend and create mechanical or safety problems during operation.

### 9. Electrical and Air Lines

Electrical and air lines extend from the front of the unit to each light and air operated component. Although they are all anchored along their routing pathways from the factory, they occasionally do come loose and will sag. Inspect all electrical and air lines. Use plastic ties to secure line to frame if any are loose and sag. Replace if any are pinched, kinked, cut or abraded. Extra care should be taken in cold or extreme operating conditions. Ice, mud or brush can pull lines loose from their anchors and cause damage. Clean components, repair damage, re-anchor and install protectors if appropriate. Do not operate with damaged components.



## 4.4 CONTROLS

Before starting to work, all operators should familiarize themselves with the location and function of all controls. Each unit is controlled from inside the tractor cab and may be equipped with an optional manual control system on the side of the trailer frame.

### 1. In-Cab Controls (Customer):

Each customer must provide controls in the tractor cab for opening and closing the discharge gates. A simple toggle switch works well for this purpose.

### 2. Midland Cab Controls (Optional):

An optional controller is available from Midland to control the opening and closing of the discharge gates and can be used with the Versa/S04 and MAC valves.

#### a. MAC Valve Control - c/w EGS:

##### On/Close

This two position toggle switch controls the power to the MAC Valve. The switch must be in the “on” position for the MAC Valve to function. **IMPORTANT NOTE:** The “off” or “closed” position cuts the power to the valve and closes the gates. In the “closed” position, the MAC Valve allows full air pressure to the closed side of the gate cylinders.

##### Indicator Light

This red indicator light comes on when power is supplied to the MAC Valve. It goes off when there is no power. NOTE: “No Power”; gates will close under full power unless air system has been completely exhausted.

##### Open

This spring loaded push button switch controls the opening of the discharge gate. Depress and hold switch until the EGS stops the gate.

##### Override

This spring loaded push button switch overrides the EGS switch. Depress and hold the switch and gates will fully open. Release the switch and the gates will stop.

#### b. Versa/S04 Valve:

##### On/Close

This two position toggle switch controls the power to the cab control. The switch must be in the **On** position for the cab control to function. The **Off** or **Closed** position cuts the power to the cab control. **IMPORTANT NOTE:** The “off” or “closed” position cuts the power to the valve and closes the gates. In the “closed” position, the MAC Valve allows full air pressure to the closed side of the gate cylinder. In the **Off** position the rocker switch (which controls the gates) will not function.

##### Indicator Light

This red indicator light comes on when power is supplied to the Cab Control. It goes off when there is no power. **IMPORTANT NOTE:** The “off” or “closed” position cuts the power to the valve and closes the gates. In the “closed” position, the MAC Valve allows full air pressure to the closed side of the gate cylinder.

##### Open/Close

This two position rocker switch controls the opening of the discharge gates. Move switch to open position and gates will open till they are stopped by the gate stops. Reverse the switch and the gates will close.



Toggle Switch (Typical)



MC/TC Train In-Cab Control

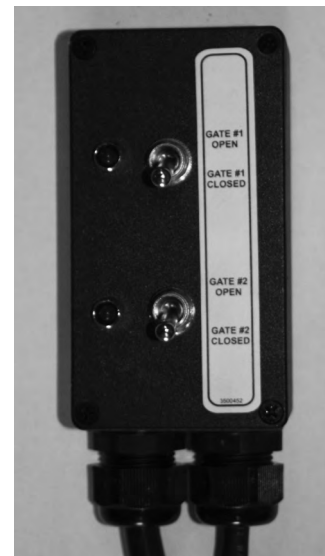

MX In-Cab Control

Fig. 2 CAB CONTROLS ALSO S04

## 4.4 CONTROLS (cont'd)

### 3. Manual Controls:

Manual controls can be mounted on the side of the frame to enable someone to walk next to the Clam unit to open or close the discharge gate(s) as required.

#### a. MAC Controls:

These switches control the opening and closing of the discharge gate(s). Depress and hold the open button to open the discharge gate(s). Release the switch to stop the gate motion. Depress and hold the close button to close the discharge gate(s). Release the switch to stop the gate motion.

#### b. Versa Control:

This three position, spring loaded to center switch controls the position of the discharge gate(s). Push on lever and hold to open discharge gate(s). Pull on lever and hold to close discharge gate(s). Release lever and it will return to its centered neutral position and the gate will stop moving.

**Extreme caution must be exercised when walking beside the trailer, to avoid slipping or falling against/under the trailer; which could result in serious injury or death.**



MAC valve configuration

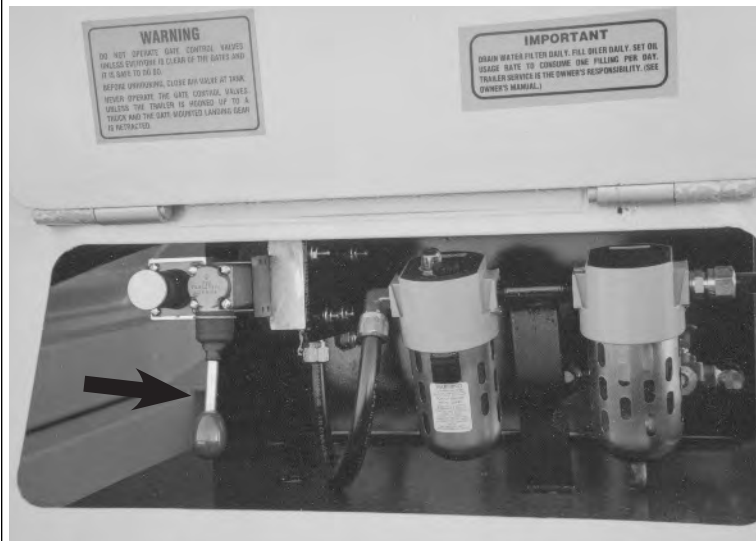

Versa valve configuration



S04 valve configuration

Fig. 3 MANUAL CONTROLS

4. **SO4 Gate Valve:**

The gate positions are controlled by an SO4 electric over air valve that directs pressurized air to either side of the cylinder as required. Pressurized air moves the cylinders to both open and close the gates. Use the stops to set the width of the gate opening. Always place the stops on each end of the gate in the same hole to prevent twisting or bending of the gate.

This valve requires only a single wire to energize it. A toggle switch in the cab is required to provide power to the valve. This valve has a manual air override. It is not used in normal dump applications and should only be used for emergency applications, eg. faulty wiring.

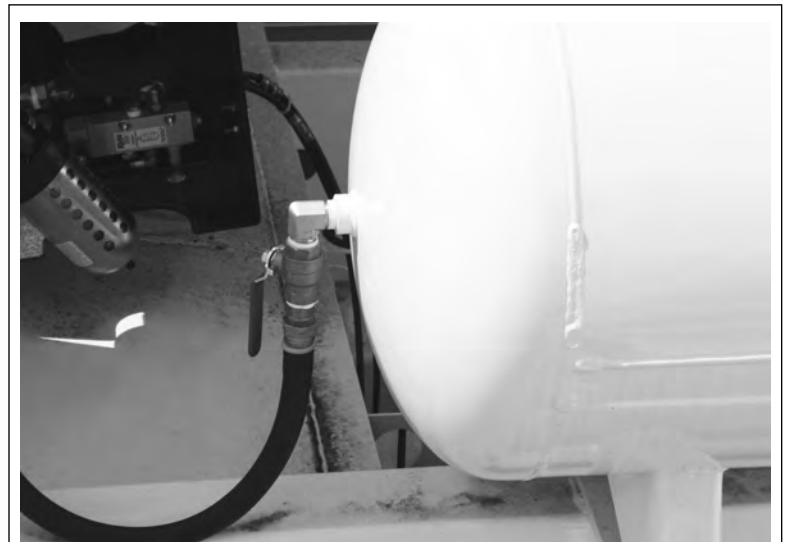

**Fig. 4 SO4 Valve/Shut-off configuration**

5. **Shut-Off Valve:**

The trailer air system supplies pressurized air to operate the brakes and the discharge gates. A shut-off valve is located downstream of the gate air reservoir and is used to isolate the gate air cylinders from the rest of the system (see note below). The operator should always turn the valve off (handle at right angles to the line) to prevent inadvertent movement of the gates. Open valve (handle parallel to the line) when the service work is completed and before resuming work.

**NOTE:** Service work on gates should never commence until the trailer air system is completely exhausted. Air can be drained more quickly by removing hose(s) to cylinder(s),



**USA configuration Clam/CUL**

**Fig. 5 SHUT-OFF VALVE**

## 4.4 CONTROLS (cont'd)

### 6. Tank Drain Valve:

Every air reservoir tank on the trailer is equipped with a spring-loaded valve that is used to drain the moisture. These valves are attached to a cable that extends out to the frame to allow the operator to drain moisture from the tanks. Pull on the cable to open the valve and drain the moisture from the tank. Release the cable to close the valve.

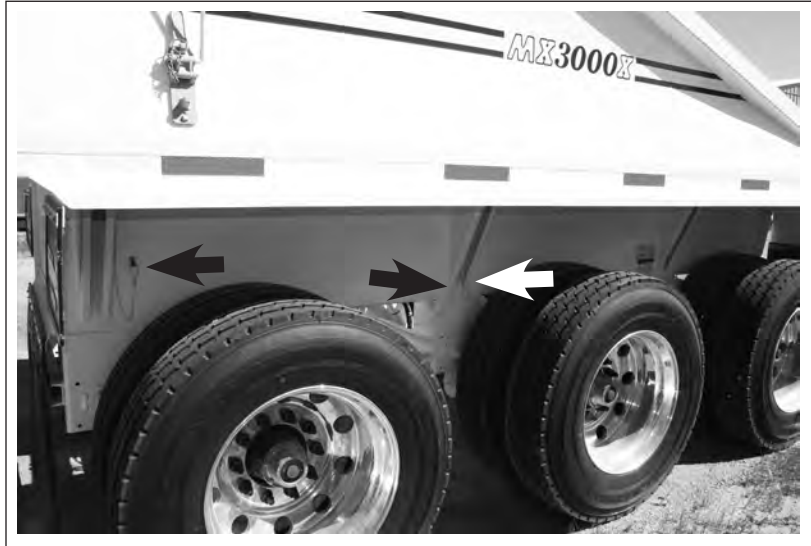
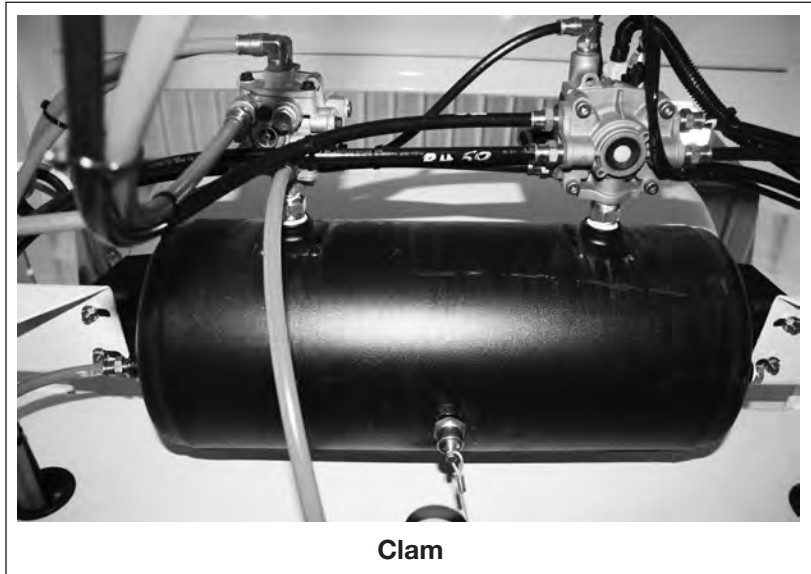

Fig. 6 DRAIN VALVE CABLE

### 7. Clam Gate Door Lock:

This pin is used to hold the clam gate in the open position. Install retainer pin, disconnect air supply sources (hose/glad hand) and drain air system completely before entering clam discharge area. **Drain system by opening drain cock at bottom of supply tank or by disconnecting air hose between tank and air cylinder. Retainer pin cannot hold clam gate open when cylinders have full air pressure. The Mac Valve will close the gate when the power is interrupted or disconnected (and there is air pressure in the system)**



Fig. 7 LOCK



8. **Landing Gear:**

A drop leg or manual crank landing gear is available for your trailer.

a. **Drop Leg:**

The drop leg type landing gear consists of an anchor bracket and extendable leg.

To extend leg, pull the pin and let the leg drop down to the ground. If an anchor hole through the leg and bracket does not line up, lift the leg until the anchor pin can be installed. The trailer will drop down on the legs as the towing vehicle pulls away. Place pads under the legs in soft conditions.

**IMPORTANT**

Do not unhook the trailer when loaded if equipped with drop type landing gear.

b. **Manual Crank:**

This landing gear uses a crank to set the position of the landing gear height. Pull the crank from its stowed position, mount on the driveshaft and push in to lock. For the high ratio drive, push the handle and driveshaft in as far as it will go. For the low ratio drive, pull the handle and shaft as far out as it will go.

When changing drive ratios, it may be necessary to turn the crank slightly to align the gears. Turn the crank clockwise to lower the legs. Place pads under the legs in soft conditions.

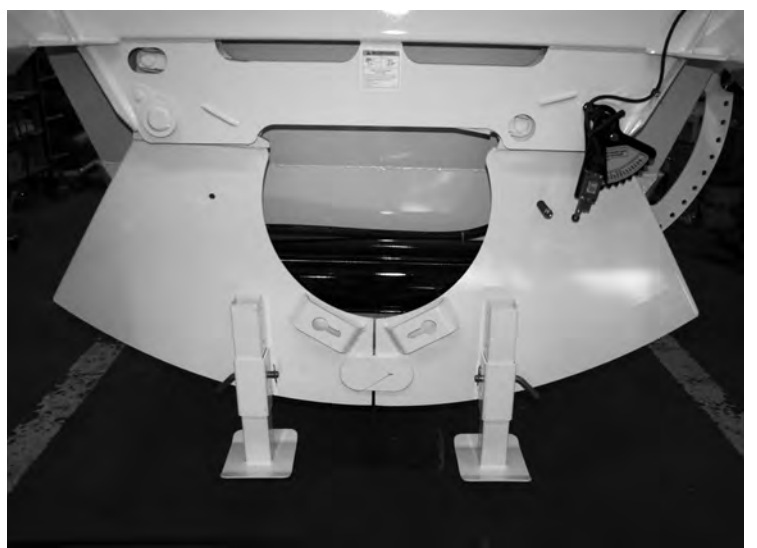

**Drop Type - Clam**



**Drop Leg - CUL  
Manual Crank (Typical)**



**Fig. 8 LANDING GEAR**

## 4.5 PRE-OPERATION VEHICLE INSPECTION PROCEDURE

The safe and trouble-free use of a Midland Trailer requires the operator to maintain the unit in good operating condition. To assist the operator, a pre-operation checklist is provided that should be followed each time before the trailer is used.

### NOTE

The tractor items, part of the Department of Transport (D.O.T.) walk around sequence, have been omitted.

### WALK AROUND SEQUENCE

#### Step 1 - Trailer Frontal Area

1. **Air and Electrical Connections**
  - a. Glad hands properly mounted, free of damage, not leaking and not worn.
  - b. Electrical line receptacle properly mounted, free of damage, plug adequately seated and safety catch engaged to prevent accidental disconnection.
  - c. Air and electrical lines properly secured to avoid tangling, snagging and chafing with sufficient slack for turns.
2. **Lights and Reflectors**
  - a. Front trailer clearance and identification lights - should be clean, operating and proper color.
  - b. Reflectors and conspicuously tape clean and proper color.

#### Step 2 - Coupling System Area

1. **Fifth Wheel (Lower)**
  - a. Securely mounted to frame.
  - b. No missing or damaged parts.
  - c. No visible space between upper and lower fifth wheel.
  - d. Locking jaws around the shank and not the head of Kingpin.
  - e. Release lever properly seated and safety latch lock engaged.
2. **Fifth Wheel (Upper)**
  - a. Kingpin not worn, bent or damaged.
  - b. Oscillating plate not cracked, bent, worn or damaged.
  - c. Oscillating bushing in good condition.

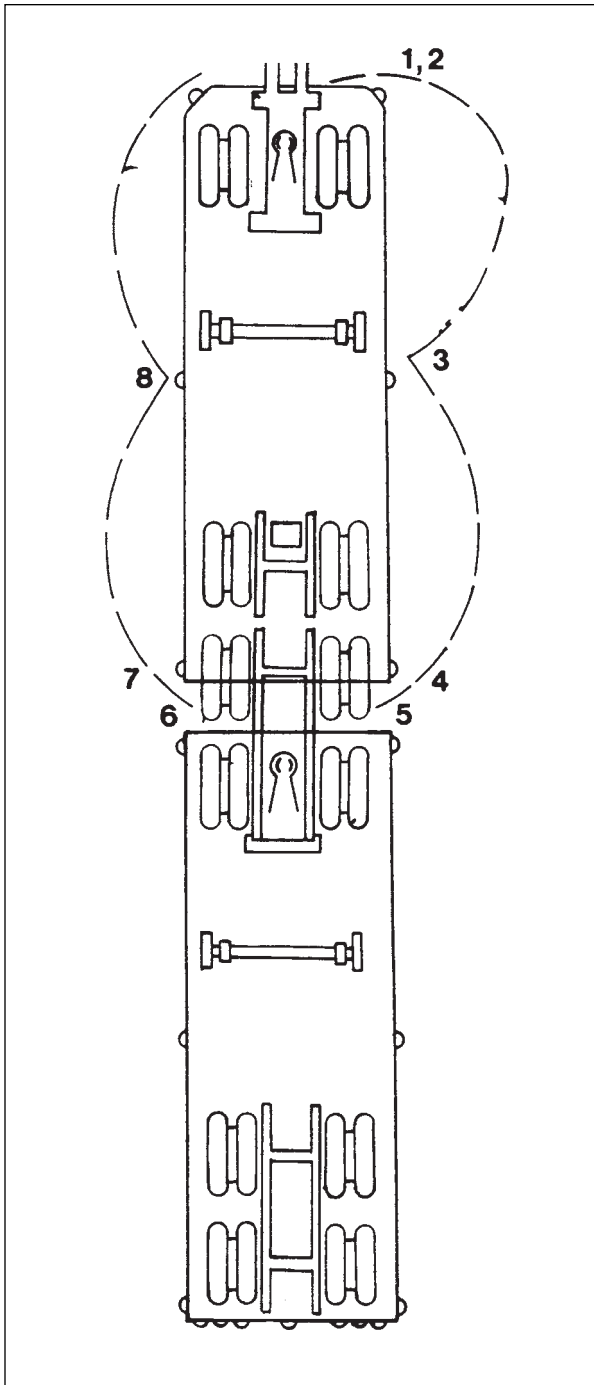

Fig. 9 WALKAROUND SEQUENCE

3. **Air and Electric Lines Visible From This Point**
  - a. Should be secure from dangling, snagging and chafing.
  - b. Should be free from damage and clean.

### Step 3 - Right of Trailer Area

1. **Front Trailer Support (Landing Gear)**
  - a. Fully raised and secured, no missing parts, not bent or otherwise damaged.
  - b. Crank handle present and secured (typically on left side).
2. **Spare Tires**
  - a. Carrier or rack not damaged.
  - b. Tire and/or wheel securely mounted in the rack.
  - c. Tire and wheel condition adequate. Proper spare tire size, correctly inflated.
3. **Lights and Reflectors**
  - a. Trailer side clearance lights clean, operating and proper color.
  - b. Reflectors and conspicuously tape clean and proper color.
4. **Frame and Body**
  - a. Frame and cross members not bent, cracked, damaged or missing.
  - b. Body parts not damaged or missing.
5. **Air Tank**
  - a. Drain moisture from air tank(s). Pull on cable attached to drain valve. Hold cable until the tank moisture is drained.
  - b. During cold weather drain moisture from the air tanks every day to prevent ice build up. During cold weather operation, use only recommended air line antifreeze in the trailer air system. Alcohol or methyl hydrate is not to be used because they will remove vital lubricants causing premature failures of valves and components. Traces of these products will void any warranty consideration.
6. **Discharge Gate(s)**
  - a. Gate stops in position and secure.
  - b. Cylinder rams clean.

### Step 4 - Right Rear Trailer Wheel Area

1. **Dual Wheels**
  - a. Condition of wheels and rims, no cracked or bent rims, broken spacers, studs, clamps or lugs.

- b. Condition of tires - properly inflated, valve stems not touching wheel rims or brake drums, valve caps in place, no serious cuts, bulges, tread wear or any signs of misalignment and no debris stuck between the tires.
- c. Tires all same type e.g. do not mix radial and bias types on the same axles.
- d. Wheel bearings and hub - no obvious oil leaks.
- e. Mud flaps in place and in good condition.

2. **Tandem or Triaxles**
  - a. Repeat wheel and tire inspection as above.
  - b. Flexible air lines not cracked, cut, crimped or otherwise damaged, secured against tangling, dragging or chafing.
3. **Suspension**
  - a. **Mechanical:**  
Condition of spring(s), spring hangers, equalizers and U-bolts.
  - b. **Air:**  
Condition of air bag(s) axle clamping bolts, pivot arm and height control valve.
  - c. Axle alignment.
  - d. Retorque all fasteners.

### Step 5 - Brakes

1. **Brakes**
  - a. Condition of brake drum(s).
  - b. Condition of hoses, lines and valves.
  - c. Check slack adjusters.
  - d. Check air chamber mounting.
  - e. Check spring brakes (if so equipped).
  - f. Drain moisture from air tank with cable.

### Step 6 - Rear of Trailer

1. **Lights and Reflectors**
  - a. Rear clearance and identification lights, clean and operating and proper color.
  - b. Reflectors and conspicuously tape clean and proper color.
  - c. Tail-lights clean, operating and proper color.
2. **Check "B" train 5th wheel:**  
Repeat same as Step 2 "Coupling System Area".

## Step 7 - Left Rear Trailer Wheel Area

Check all items as done on right side (Step 4 "Right Rear Trailer Wheel Area").

## Step 8 - Left Side of Trailer Area

1. Check all items as done on right side (Step 3 "Right of Trailer Area").
2. **Gate Air System**
  - a. Drain water from filter cannister. Clean or replace filter as required.
  - b. Fill oiler with light grade of oil.

## Step 9 - Trailer(s) Functional Check (Tractor Attached)

1. Check for proper connection of the air brake glad-hands and secure contact of electrical connection.
2. Start engine.
3. Build up air pressure in the tractor-trailer systems.
4. Turn on lights and inspect for proper function of:
  - a. Clearance lights.
  - b. Identification lights.
  - c. Turn signals and 4-way flasher.
  - d. Sidemarkers lights.
  - e. Tail lights.
  - f. Stop lights.
5. Check the function of brakes.
  - a. Apply service brakes.
  - b. Apply parking brakes.
  - c. Apply emergency brakes.
  - d. Stop engine.

- i. Release trailer emergency brakes.
- ii. Apply service brakes

Air loss should not exceed  
3 psi per minute on single vehicles.  
4 psi per minute on combination.

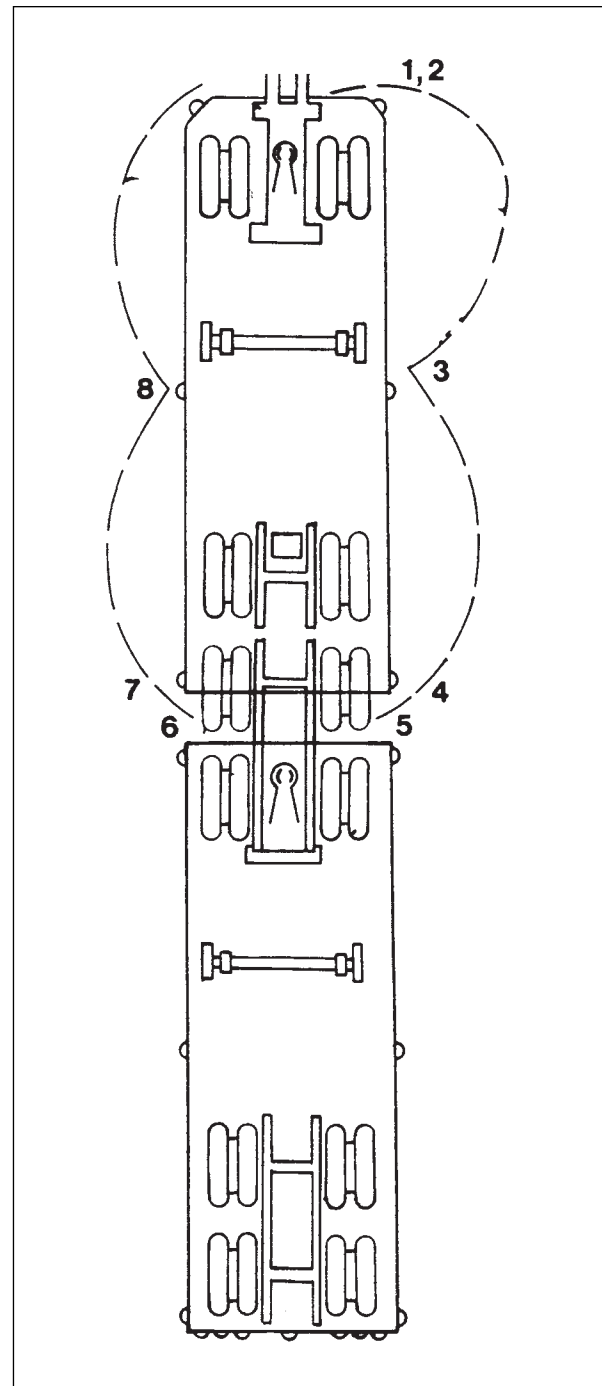

Fig. 10 WALKAROUND SEQUENCE

## Step 10 - On Trailer Transporting Hazardous Material

1. Check marking and placards.
2. Check for proper shipping papers.



## 4.6 HOOKING UP/UNHOOKING

Special care should be taken when hooking up or unhooking trailer to be sure the equipment is in good condition and all systems are functioning as required.

### 4.6.1 HOOKING UP

Follow this procedure when hooking up the trailer to towing vehicle (tractor or lead trailer):

1. Back the towing vehicle up in a straight line to the trailer and align the fifth wheel opening with the trailer king pin.
2. Stop before the fifth wheel makes contact with the trailer and apply the towing vehicle parking brake.
3. Inspect all the coupling components before hooking up:
  - a. Inspect trailer coupling components. Check that king pin is not broken, bent or chipped. Check that the oscillating plate is not bent or cracked. Check that the pivot bushings are in good condition and that the mounting fasteners are tightened to their specified torque. If problems found, correct before proceeding.
  - b. Inspect fifth wheel coupling components. Check that the fifth wheel assembly is securely anchored to the B train or tractor frame. Check that the structure of the frame, pivot and fifth wheel is not bent, broken or cracked. Check that the jaws of the lock are open. If problems found, correct before proceeding.
  - c. Be sure that the fifth wheel plate is cleaned and greased.
4. Open the coupler lock.
5. Tilt the fifth wheel plate back.
6. Check that the trailer is at the required height to slide onto the fifth wheel.
  - a. Use the crank on the landing gear to raise or lower the trailer as required.
  - b. On drop leg landing gear, care must be taken if the trailer is too low to climb up on the 5th wheel. It may be necessary to raise the trailer and repin the drop legs.

The trailer oscillating plate should contact the fifth wheel just behind the pivot point as the towing unit backs under the trailer.



Fig. 11 COUPLING COMPONENTS

7. Block the trailer wheels.
8. Connect brake lines. Route the lines so they do not get pinched when the trailer is attached to the tow unit.

9. Check brake application by applying and releasing brakes. If brakes do not release, air lines may be crossed. Do not continue unless brakes are functioning properly.
10. Re-apply trailer brakes using trailer hand valve.
11. Back slowly under trailer keeping the king pin centered in the fifth wheel jaws.
12. Back up until the fifth wheel coupler locks on the trailer king pin.
13. Gently move the towing vehicle back and forth while the trailer brakes are engaged to check that the jaws have locked around the king pin.
14. Set parking brake, stop engine and dismount.
15. Visually check that the coupler jaws are securely locked around the king pin and the coupler release lever is in the locked position. Release and hook up again if the jaws are not securely locked around the king pin.

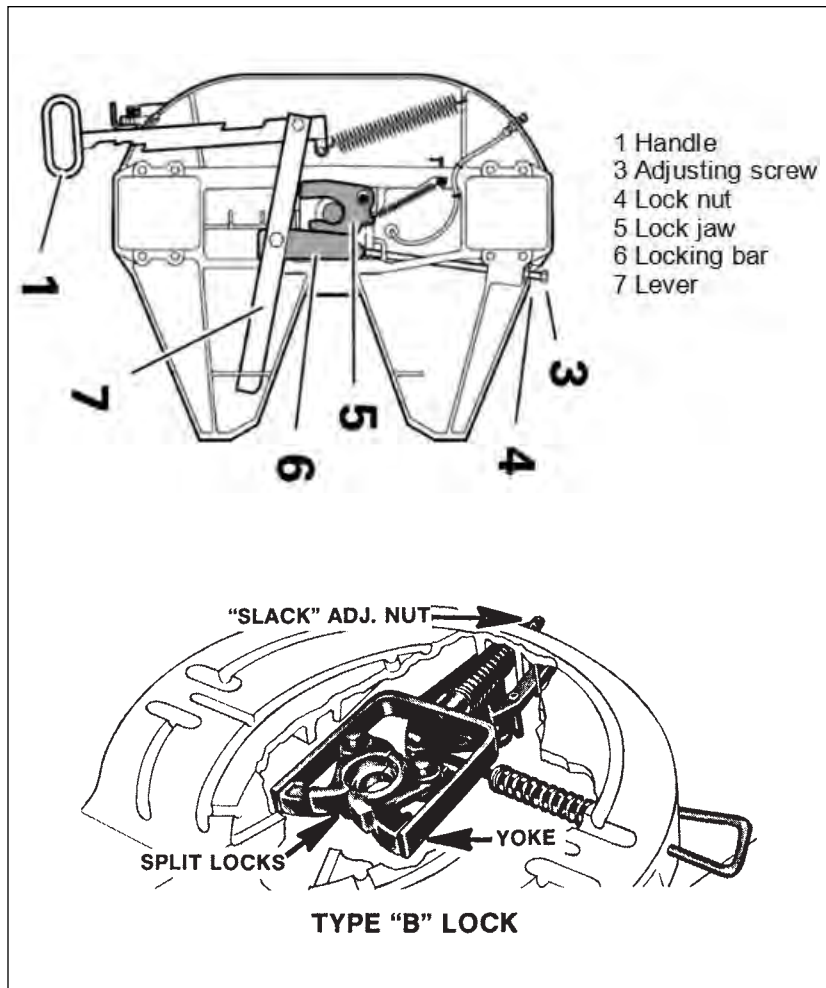

**Fig. 12 COUPLER LOCKS**

16. Check that the trailer oscillating plate is resting on the fifth wheel.
17. Connect and secure the electrical terminal. Check that all electrical circuits are completed and that all lights are working.
18. Route the electrical and air lines to prevent snagging, dragging and pinching.
19. Raise the landing gear.
  - a. Remove the anchor pins, raise leg and repin on the drop leg style.
  - b. Use the crank to raise the legs if equipped with the crank style. Stow crank.
20. Remove blocks or chocks from the wheels.
21. Perform Pre-Trip Inspection before starting.

## 4.6.2 UNHOOKING

1. Position towing unit and trailer in a straight line on a clear, level and firm surface.
2. With Clam system, close discharge gates so the legs are directed straight down.
3. Apply the trailer brakes and the parking brakes on the tractor before dismounting.
4. Place blocks or chocks in front of and behind trailer wheels.
5. Place large blocks or planks under landing gear if the ground is soft.
6. Lower landing gear:
  - a. Remove pins from legs of drop leg style landing gear. Raise leg slightly if required to install anchor pin.
  - b. Use crank to lower leg on crank style landing gear. Lower leg until pads solidly contact the ground but do not lift trailer off fifth wheel. Stow crank.
7. Unhook fifth wheel coupler.
8. Charge trailer air system and apply brakes using trailer hand valve.
9. Release tow unit parking brake and pull slowly forward until the trailer apron just slides down the fifth wheel ramp. Stop.
10. Set the parking brake on the tow unit before dismounting.
11. Check that the surface under the landing pads can support the trailer. Support with blocks or planks if required. This is particularly important if the trailer will be loaded while unhooked.
12. Disconnect air line and electrical connector.

### IMPORTANT

Only crank type landing gear can support a loaded trailer.

13. Install glad hands on dead end connectors if so equipped.
14. Drive tow vehicle away from trailer.
15. Inspect the equipment. Document problems found so they can be corrected before the unit will be used the next time. Record problems and repairs for your files.

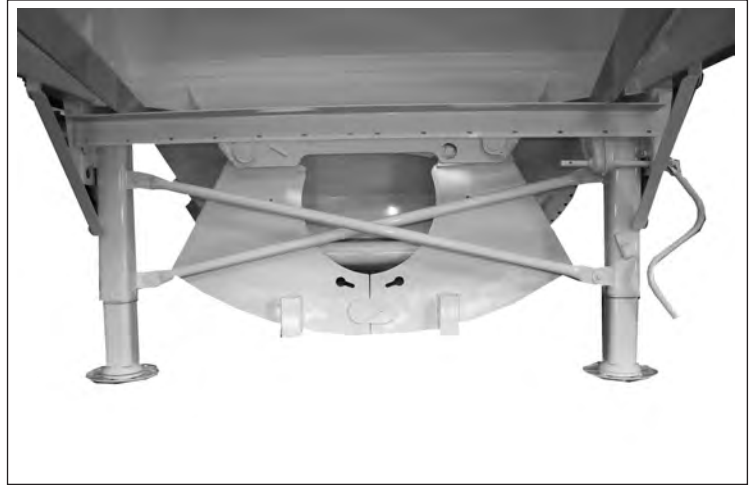
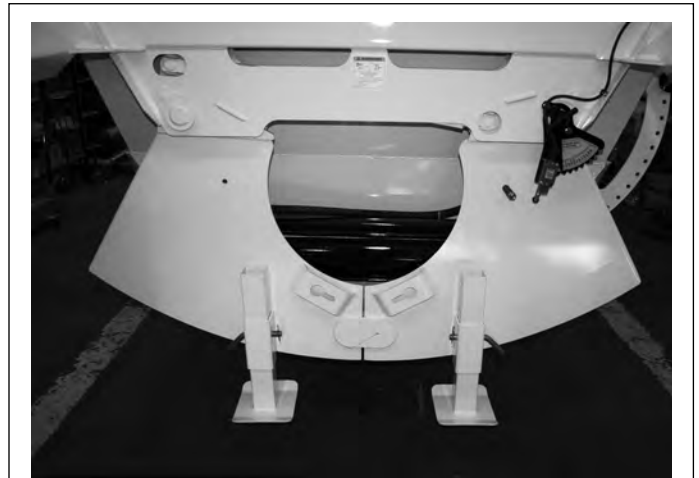

Fig. 13 CLAM GATES



Clam



CUL

Fig. 14 UNHOOKED

## 4.7 DISCHARGE GATES

### IMPORTANT

Before adjusting gates, power unit (truck) must be shut-off and the key removed from the ignition.

The trailers can be designed with a clam or cross dump discharge gate style. Each design fulfills certain requirements by customers.

### 4.7.1 CLAM SHELL DISCHARGE GATE

The clam shell discharge gate style is designed so the gates are aligned parallel with the trailer body or the direction of travel. Air cylinders on each end of the gate control the gate for opening or closing.

Controls are located in the cab or on the side of the trailer frame. Gate opening width is set by placement of the outboard adjustment locks or by setting the length of the gate chains (Optional EGS available). Equalizer arms in the gate opening linkage will open both ends of the gate equally.

Use either of these methods to set and maintain a desired opening when windrowing or discharging at a controlled rate.

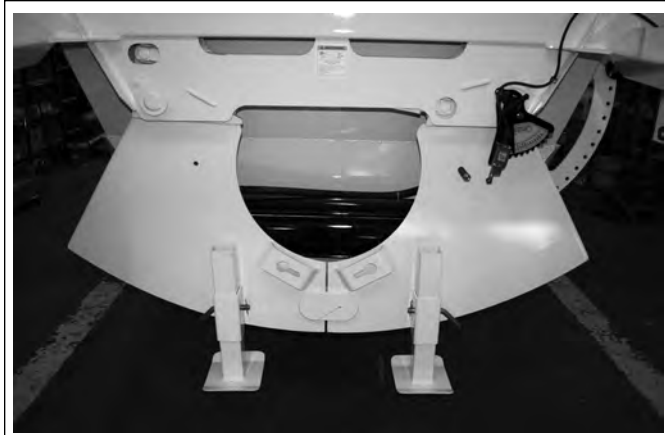

Inboard cylinder mounting protects from truck debris. Front



Internally mounted rear cylinder.



Externally mounted rear cylinder.



Stops

Fig. 15 CLAM DISCHARGE GATE

## 4.7.2 CLOSE UNDER LOAD (CUL) GATES

The cross dump gate style is designed so the gates are aligned at right angles to the body or the direction of travel. Double acting air cylinders are used to control the position of the gates for opening and closing on the CUL model.

Both cylinders can be operated together or individually depending on the air system plumbing and application requirements. When operated individually, there are separate toggle switches and air system solenoid control valves for each dump gate. By placing the optional divider in the hopper, two different types of material can be carried.

On the close under load style, use the adjustable settings on the sliding tubes; along side the cylinders, between the hoppers.

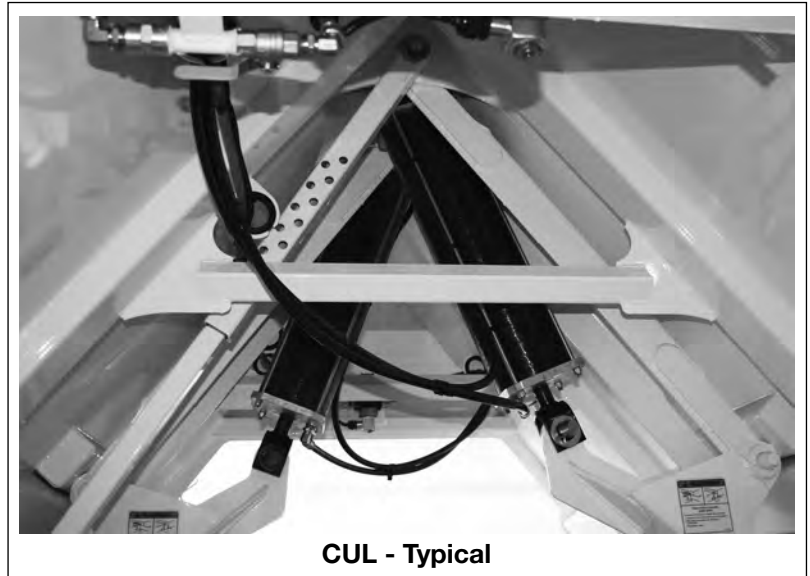

**Fig. 16 GATE STOPS**



## 4.8 AIR SYSTEM

Pressurized air is used to operate the opening and closing of the gate(s) on the trailers through a series of components: filter, oiler, electric solenoid, tank(s), cylinder(s) and lines. All components work together to control the gates.

### 4.8.1 FILTER AND OILER \*CLAM ONLY

The air system is designed with a filter and an oiler to remove contaminants from and add a light oil mist to the air supply.

#### A. Filter:

The self draining filter insures that only dry air is used to move the air cylinders for opening and closing the discharge gates. Any moisture in the air will wear the seals and packing in the cylinder or freeze in cold weather. Check daily, drain if required.

#### B. Oiler:

The oiler introduces a fine oil mist into the air stream as it moves into or through the cylinder. The oil mist lubricates all the internal and moving cylinder components. Without oil, the seals and wipers in steel cylinders will dry out and wear rapidly until the cylinder fails.

Keep oil in the oiler at all times. Establish the oil consumption rate for your application and add oil before the oiler is empty. Refer to Section 5.2.16 for filling and adjusting procedure. Check the oil level on a daily basis.

**NOTE: Composite cylinders do not require filter and oiler**

**NOTE: The standard cylinder on the CUL trailers is the composite cylinder, hence oilers are not required.**



USA steel cylinder configuration Clam Gate



Mac Control



S04 Control

Fig. 17 FILTER AND OILER

## 4.8.2 TANKS

Pressurized air from the tractor air compressor feeds into the tanks until it is needed by the brakes and tanks. In this way each system will have sufficient air at the appropriate pressure to provide the required response.

Pull the cables on the valves to drain moisture from the tanks every day or more frequently in high humidity or cold temperature conditions.

### IMPORTANT

Recent revisions to DOT regulations mandate higher pressure levels in trailer air supply lines. Do not compromise gate or braking performance with low pressure. Check your tractor. Set the compressor cut-in pressure to 105 psi and cut-out to not more than 120 psi.

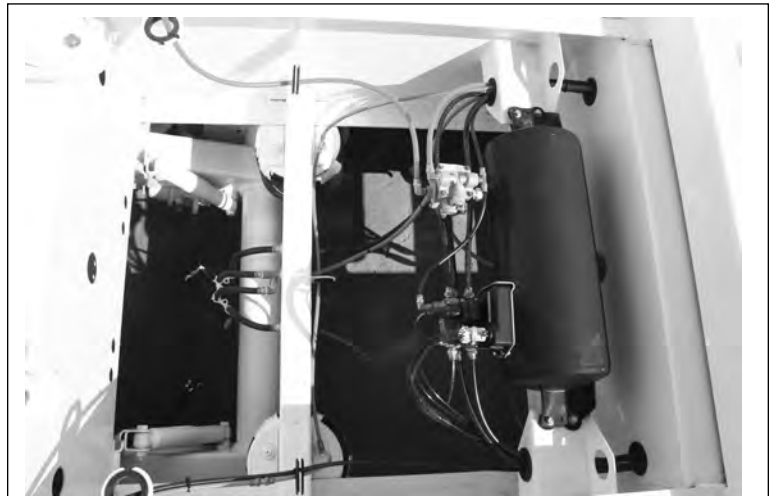

**Brakes**

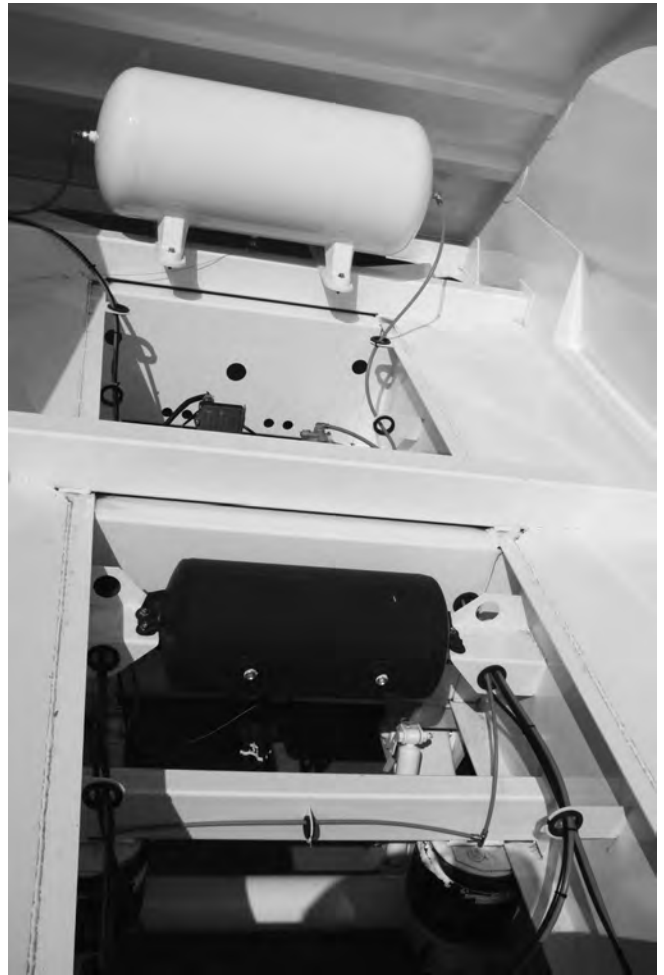

**CUL Tanks**

**Fig. 18 TANKS (TYPICAL)**

## 4.8 AIR SYSTEM (cont'd)

### 4.8.3 CYLINDERS

Six or eight inch cylinders are used to open and close the discharge gates. Switches in the cab or on the side of the frame of the trailer control the air flow to the cylinder(s). A filter and an oiler in the system provide clean, lubricated air to each cylinder to insure long life.

Composite cylinders are optional on the Clam Trailer and standard on the CUL trailer.

Trailers equipped with the composite cylinders do not need the filter and oiler.

Keep the cylinder rams clean at all times to prevent damaging the seals or wiper. This is particularly true when hauling hot asphalt, which can splash when dumping and stick to the ram. Clean rams before retracting.

**NOTE: Be sure to keep arms, legs and body away from the gates.**



Clam Shell

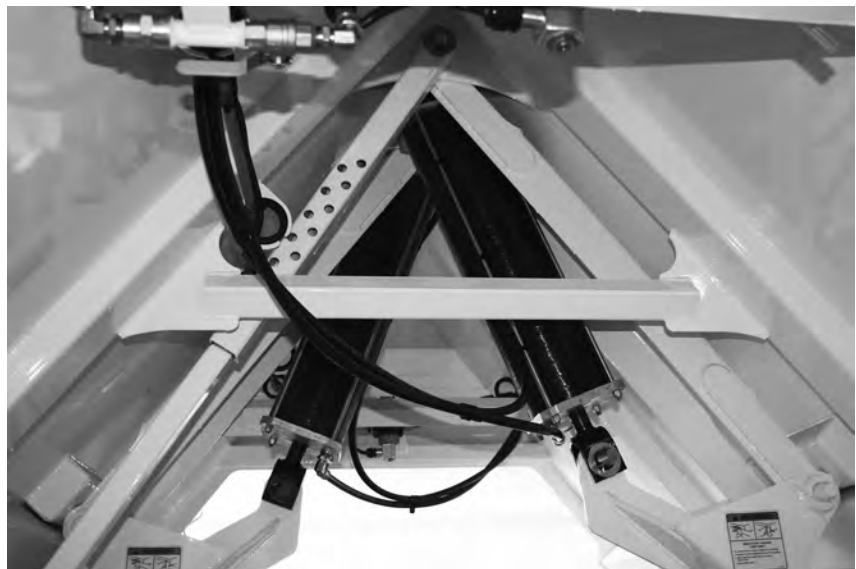

CUL

Fig. 19 CYLINDERS



## 4.9 LOADING/UNLOADING

It is the responsibility of the operator to review and be familiar with the trailer loading capacity specifications and be sure that you comply with any and all load limitations or restrictions applicable in the jurisdictions where you will be travelling. Exceeding the trailer weight specifications can result in damage to the structure and voids the manufacturer's warranty. Exceeding the road restrictions is illegal.

Loading/unloading procedures and instructions are covered but not limited to those summarized below:

### A. Loading

1. Clear the area of bystanders and remove debris from loading area.
2. Position the trailer as required and set park brake before dismounting.
3. Be sure discharge gates are closed and trailer air system is charged.
4. Minimize the drop height when loading.
  - a. Position the loading equipment as close to the bottom of the trailer as possible.
  - b. Do not load trailer unless hooked to towing unit.
5. Do not drop large dense objects into the trailer as they can damage the structure.
6. Distribute the material evenly from side-to-side and front-to-rear during loading to equalize the structural and axle loading during transport.
7. Secure the trailer cover as required.



Fig. 20 LOADING



Fig. 21 COVER

## B. Unloading

1. Clear the area of bystanders and remove debris from unloading area.
2. Set gate opening width.
3. Open or remove the tarp if so equipped.
4. Proceed to the unloading area.
5. Use toggle switch(es) in the cab to open the gate the desired amount.

### IMPORTANT

Use care when applying brakes, while backing up a trailer equipped with an Air-Ride suspension system. When applying the brakes aggressively, the axle dynamics can result in the air spring over-extension and can cause component damage. No damage will occur with slow speeds and gradual braking.

6. When windrowing or spreading the load over a surface, combine the vehicle speed with the amount of gate opening to produce the desired material thickness over the dump area.

### NOTE

The most consistent results are obtained by using the discharge gate anchor lugs to set the gate opening width (or setting the EGS System if the Clam Bottom Dump is so equipped).

7. When unloading with a partner, always have constant visual contact with your partner before operating a discharge gate. It is recommended that only the partner operate the discharge gate(s).

When unloading, the partner can operate the discharge gates with the manual controls on the side of the trailer frame. Do not exceed a safe walking speed for your partner. (#7 relates primarily to the Clam Bottom Dump trailer)

8. When handling material that does not flow evenly or requires dislodging, use extra care. A long stick or long handled shovel should be used while standing outside the trailer. Have a back-up person there in case a problem arises. **Use common sense. Do not enter trailer through a discharge gate unless the line valve is turned off, the air system is completely exhausted and gates locked in open position.**

### NOTE

When power is interrupted or disconnected (and the trailer has full air pressure) the mac valve will close the gates.

Use the gate safety retainer only when the air system has been completely exhausted.

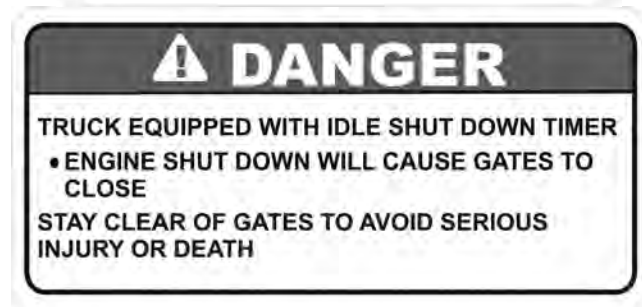

9. Know the characteristics of the material being handled. Never enter the trailer if toxic material is being handled.

## **4.10 TRANSPORTING**

By following the previous instructions, your Midland trailer unit has been hooked-up and is ready to go. Although all operating instructions are common sense, it is wise to review them periodically to refresh your memory. Good operational procedures result in a safe workplace for the operator and others.

### **4.10.1 OPERATING INSTRUCTIONS**

Since this equipment can be used in a variety of conditions, it is difficult to give instructions appropriate for all applications. However, these general guidelines apply to all situations:

1. Be sure that the trailer is securely attached to the towing vehicle or lead trailer and locked into position.
2. Be sure that the air lines are securely connected and that they have sufficient slack for turns.
3. Ensure that the brakes are properly adjusted and in good working condition.
4. Ensure that the electrical harness is securely attached and all lights and reflectors are clean and operating.
5. Maintain the mud flaps in good condition to minimize road splash in wet conditions.
6. Always maintain the trailer in good mechanical condition.

## 4.10 TRANSPORTING (cont'd)

### 4.10.2 BRAKING GUIDELINES

Safe, reliable and trouble-free operation of your trailer requires that the brakes be maintained in good operating condition at all times and the driver follows good application techniques when driving. The irresponsible use of brakes by the driver when traveling can contribute to low brake life or result in system malfunctions, short life and poor tire wear patterns. The following list summarizes some basic operational guidelines for the driver.

1. Check the function of the brake system before starting a trip.
2. Maintain a safe vehicle speed at all times. Slow down for rough road or slippery surface conditions, winding roads or congested areas.
3. Always provide sufficient vehicle spacing on the road to allow for a safe stopping distance.
4. Apply brakes gradually to produce an even deceleration until the vehicle is stopped.
5. Watch traffic patterns ahead. Anticipate pattern changes that could result in an emergency. Apply the brakes gradually in sufficient time to produce a controlled stop.
6. Shift to a lower gear to use engine compression as the retarding force when going down steep grades.
7. Do not apply brakes for a long period of time such as when traveling on a long downgrade. The brakes will overheat. Instead, apply both the tractor and trailer brakes for short periods of time giving the brakes a chance to cool between applications.
8. Dry the brakes by applying them several times after going through water.
9. Release the brakes just before going over railroad tracks or other rough conditions. By allowing the wheels to turn over rough road surfaces, there will be no shock loads to the brake system components or produce flat spots on the tires.
10. Wet, icy or snow-packed surfaces require special care. Make cautious, intermittent applications by fanning or pumping the brakes to reduce speed without skidding or locking the wheels.
11. Use caution when applying the tractor driveline brake should you lose the service brake system. Rapid and hard application of the driveline brake can result in axle or driveline component failures with the resulting loss of all braking systems.
12. Use wheel chocks, apply trailer and tractor parking brakes and place tractor in low gear when parking the unit.
13. Maximum brake retarding occurs just before the wheels lock up and the tires skid. Release the brakes should you feel them lock-up and reapply them.
14. When trailer brakes are applied with hot drums, it may result in a cracked drum. Allow them to cool before reapplying the brakes.
15. Fanning or repeated on-and-off applications will use up the system air reserves. This procedure is not recommended unless adverse road conditions are encountered. The wasting of air reserves in this way could result in insufficient application pressure should an emergency arise.
16. Hard or panic stops can overheat the linings and drums. Overheating will cause brake fade. Severe overheating and fade can result in the complete loss of braking capability. This will substantially reduce the expected life of brakes.

### 4.10.3 TIRES

When operating the trailer, it is the responsibility of the driver to check the tires frequently. Inflation pressures, wear patterns and matching are critical parameters that must be monitored. The following factors affect tire care:

1. **Inspection frequency:** Tires should always be checked before the start of a run and twice during the day or every 4 operating hours, whichever comes first. It is also a good practice to check the tires at each rest period during the day. When a driver hears unusual noise or experiences unusual handling characteristics, the first item to check is the tires. Problems found early, during frequent tire checks, can save more serious problems later on. A sampling of typical abnormal wear patterns are shown in the Maintenance section along with their causes. Always correct the cause of the tire wear problem before proceeding.
2. **Inflation pressure:** Tires should always be operated at their specified pressures. At their specified pressures, the tire is designed to run with the full width of the tread flat on the contact surface. Operating at other than specified pressures will change the tread contact patterns and can dramatically shorten tire life. In addition, the tires will run hotter and can lead to blow-outs.

Check tire pressure when the tire is cold. A hot tire can read as much as 20 psi higher than a cold tire. If tires are over-inflated, check for poor load distribution, uneven surface contact, over-loading or poor operating conditions.

3. **Tire matching:** Do not mix ply types on the same axle. Their operating characteristics are different and will lead to uneven tire loading, rapid tire wear and adverse handling characteristics. Matching also includes combining tires that have the same amount of tread remaining. A tire with more tread has a larger rolling radius and will have to carry a higher load. The best performance will be obtained when the rolling radius is within 1/8" for all tires on an axle.

## 4.11 OPTIONAL EQUIPMENT

The trailers can be equipped with several options or attachments to adapt it to special customer requirements.

### 1. **Shed Plates:**

Plywood shed plates can be mounted on the frame to prevent a build-up of material on ledges, fenders and other flat surfaces and to protect air and electrical system during loading. Always remove material from the shed plates prior to getting on the highway.



Fig. 22 SHED PLATES

### 2. **Push Block:**

Reinforced push blocks are available to attach to the back of the frame. This block will provide a place for other equipment to push on the trailer should the need arise. The push block is not intended to be and should not be used as a lifting device.



Fig. 23 PUSH BLOCK with Under Run Bumper

### 3. **Axle Rock Guards:**

Full width or individual rock guards are available to protect the air brake chamber as the load is being discharged. Their use is recommended when unloading at a higher rate of speed or when discharging larger rocks or clumps of material. The Hendrickson Intraax suspensions do not need axle guards; given the location of the air pots and slack adjusters.



Fig. 24 AXLE ROCK GUARD



4. **Electronic Gate Stop (E.G.S.) - Patent Pending:**

The E.G.S. is a unique Midland innovation allowing the operator complete control of the clam gates from the comfort of his truck cab. The system has four main components: Mac Valve, Gate Stop Switch, Open/Close Push Button Station and In-Cab Control.

a. **The MAC Valve:**

Allows operator complete control of the clam gates. The gates can be stopped at any position while opening or closing the gates.

b. **The Gate Stop Switch:**

Is mounted on the clam gate hangers. It can be adjusted for an infinite number of gate openings. When the gates open, the stop pins (located on clam doors) contact the stop switch and stop the movement of the gates at the preset opening (location). The in-cab control allows the operator to override the gate stop and fully open his gate for clean out.

c. **A Push Button Station:**

Is located at the rear on the driver side of the trailer. The gates can be opened and closed with this control and will override the gate switch.

d. **The In-Cab Control:**

Consists of an on/off toggle switch, an open and override switch (button) which control all the E.G.S. functions. The toggle switch must be in the on position for any of the E.G.S. controls to function (including push button station). The open switch (button) opens the gate until the gate pin makes contact with the gate switch and stops the gates. The Override Switch (button) bypasses the gate stop switch and allows gate to be fully opened. This button also allows operator to jog gates to desired opening. The "Off" position on the toggle switch closes the gates. While closing the gates moving the toggle switch to the "On" position stops the gates.



Fig. 25 ELECTRONIC GATE STOP (E.G.S.)



Fig. 25 ELECTRONIC GATE STOP (E.G.S.)



Fig. 25 ELECTRONIC GATE STOP (E.G.S.)

## 4.11 OPTIONAL EQUIPMENT (cont'd)

### 4. Cover:

A solid or mesh vinyl cover is available to cover the load in the trailer. It prevents the material from blowing out of the trailer. It is recommended that a cover of some kind be used whenever transporting a load on a public highway. Several different models of covers are available; Flip Tarp or Gravel Guard Slider Tarp with electric, air or manual crank options.



Fig. 26 COVERS



# 5 SERVICE AND MAINTENANCE

This section provides information on daily and periodic service and maintenance of the Trailer unit. Follow these recommendations for safe and dependable operation of the Trailer unit. Refer to the safety section at the front of the operator's manual for all applicable safe maintenance and operating procedures.

Be sure that all operators are familiar with the operation and maintenance procedures and related safety information contained in the operator's manual.



## MAINTENANCE SAFETY

1. Read and understand all the information in the Operator's Manual regarding maintenance, adjusting and servicing the Trailer unit.
2. Place all controls in neutral, stop the engine, remove ignition key and set the park brake before adjusting, servicing or maintaining any part of the Trailer unit.
3. Follow good shop practices:
  - Keep service area clean and dry.
  - Be sure electrical outlets and tools are properly grounded.
  - Use adequate light for the job at hand.
4. Cage spring brake chamber before disassembling.
5. Block wheels before de-activating brakes.
6. Disconnect air lines and exhaust air system completely before working on discharge gates.
7. Maintain fasteners in running gear systems at their specified torque at all times.
8. Establish and maintain a Trailer Preventative Maintenance (TPM) program on your equipment. Some jurisdictions require this program and the maintenance of records on every commercial vehicle on the road for future reference.

## 5.1 SERVICE

### 5.1.1 FLUIDS AND LUBRICANTS

1. Grease:  
Use an SAE multi-purpose lithium based grease with extreme pressure (EP) characteristics.
2. Wheel Hub Oil:
  - a. Use an SAE 80W90 for normal temperature conditions (-10°F to 100°F ambients).
  - b. Use an SAE 85W140 for hot temperature conditions (100°F and hotter ambients).
  - c. Use an SAE 30W motor oil for ambients below -10°F.  
Capacity: 1 pint (500 ml)
3. **General Purpose:** I.S.O. Viscosity Grade 32 at 40°C
  - ESSO - NUTO H 32
  - SHELL - TELLUS 32
  - PETROCAN/ -
  - GULF - HARMONY AW 32**Extreme Low Temp.:**
  - ESSO - UNIVIS N 32 (-10°C - 40°C)
  - UNIVIS N 22 (-20°C - 0°C)
  - UNIVIS N 15 (-40°C - 0°C)

#### NOTE

The general purpose I.S.O. 32 are equivalent to SAE 10, Mobile DTE Light as mentioned in Wilkerson Catalog 173, page 19.

4. Storing Lubricants  
Your Trailer can operate at top efficiency only if clean lubricants are used. Use clean containers to handle all lubricants. Store them in an area protected from dust, moisture and other contaminants.

### 5.1.2 GREASING

Refer to Section 5.1.1 for recommended grease. Use the Service Record checklist provided to keep a record of all scheduled servicing.

1. It is recommended that a hand-held grease gun be used for greasing. An air-powered greasing system can damage the seals on bearings and lead to early failure.
2. Wipe grease fitting with a clean cloth before greasing, to avoid injecting dirt and grit.
3. Replace and repair broken fittings immediately.
4. If fittings will not take grease, remove and clean thoroughly. Also clean lubricant passageway. Replace fitting if necessary.

### 5.1.3 SERVICING INTERVALS

A standard servicing schedule is provided as a guide for your convenience. In unusual or extreme operating conditions, increase the frequency or perform additional service items to customize this schedule to your application.

**Your Midland Gravel Trailer is equipped with Duralon Bushings at all major pivot points. These high performance bushings do not require lubrication or any other maintenance. The Teflon Fibers woven into the bushing liner provide the lubrication.**

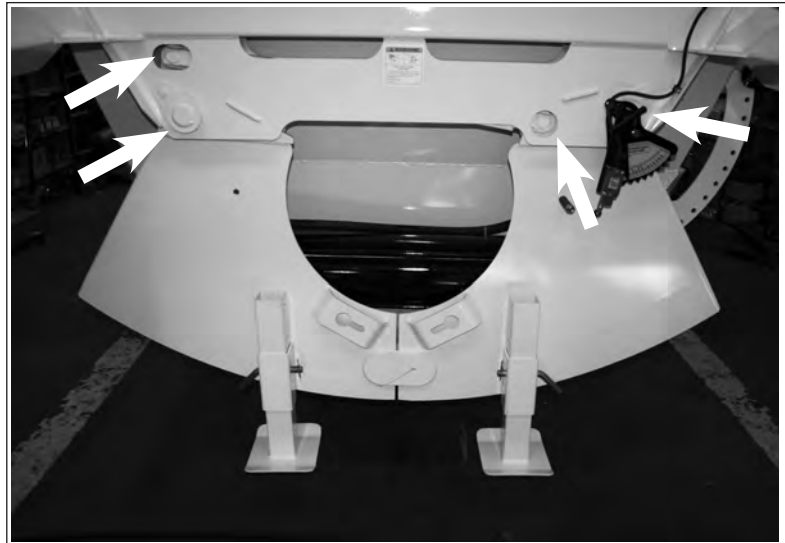

Fig. 27 PIVOT POINTS (TYPICAL)

#### 8 Hours, Daily or 500 Miles

1. Fill oiler reservoir.

**NOTE:** read section 5.2.16 for important oiler information



Fig. 28 OILER

2. Drain moisture from air tanks (use cables to open drain valves).

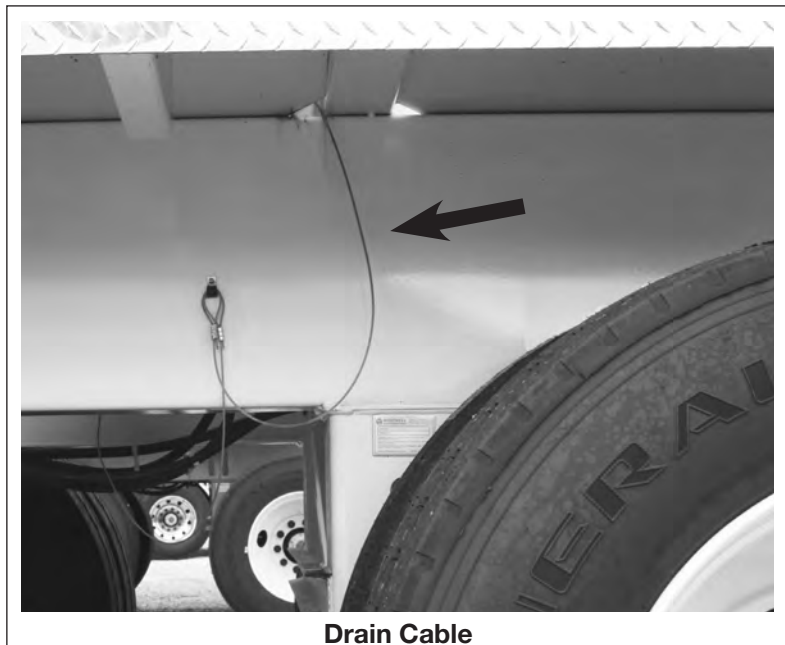

Fig. 29 DRAIN CABLES (TYPICAL)

**8 Hours, Daily or 500 Miles (cont'd)**

3. Drain moisture from water filter cannister in air line (1 location at front of trailer).



**Fig. 30 AIR FILTER CANNISTER**

4. Check tire air pressure. Add as required.



**Fig. 31 TIRES (TYPICAL)**

**Weekly, 10 Days or 5000 Miles**

1. Grease slack adjusters.  
Refer to Haldex Service manual.
2. Refer to Haldex Brake Systems manual.
3. Grease fifth wheel.
  - a. Pivots (2 locations).
  - b. Surface
4. Clean the water filter in the air line.
5. Check wheel hub oil levels.

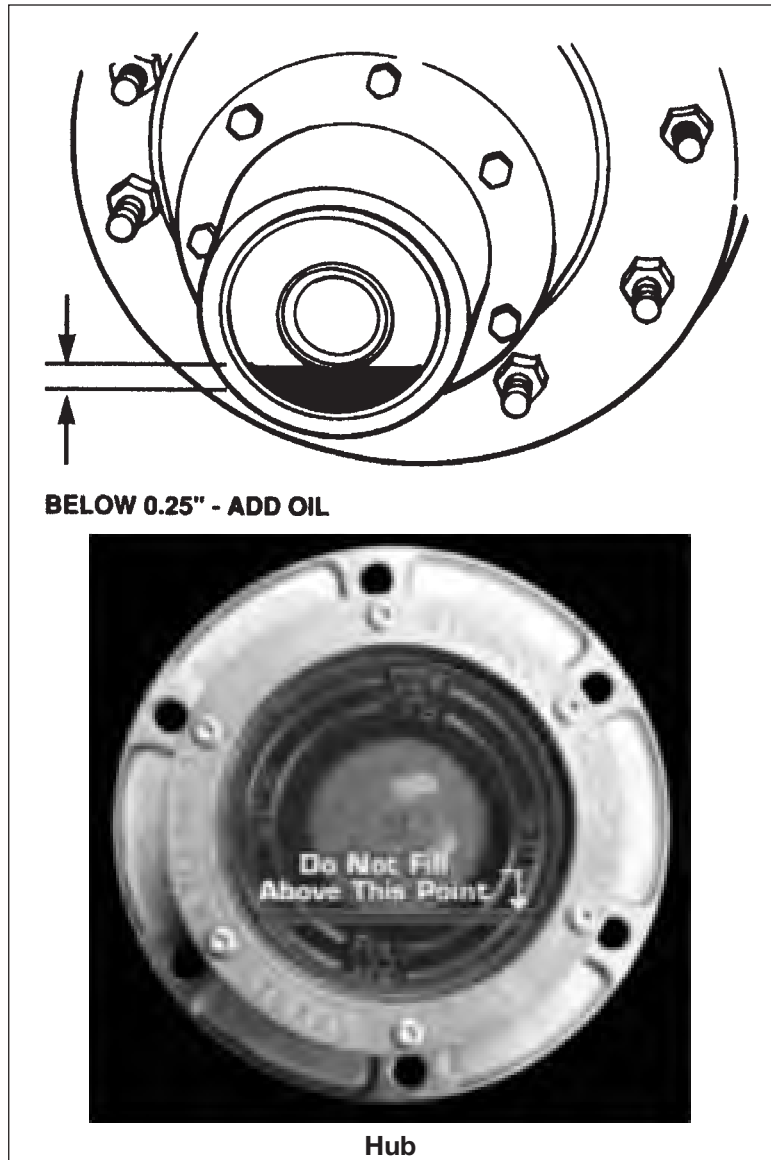
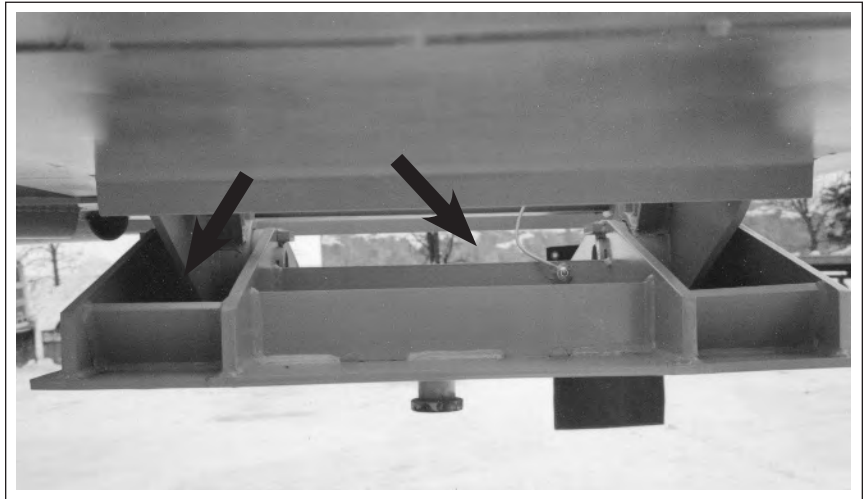

**Fig. 32 HUB OIL LEVEL**

**Weekly, 10 Days or 5000 Miles (cont'd)**

6. Retorque the following fasteners:

a. Oscillating plate bushing anchor bolts to 250 ft. lbs.



**Fig. 33 BUSHING ANCHOR BOLTS**

b. Brake/wheel end system fasteners.  
Refer to Section 5.2.8.

**WARNING!** Failure to follow this instruction could cause the wheel to come off and cause bodily injury. Failure to back off the nut will cause the bearing to run hot and be damaged.”

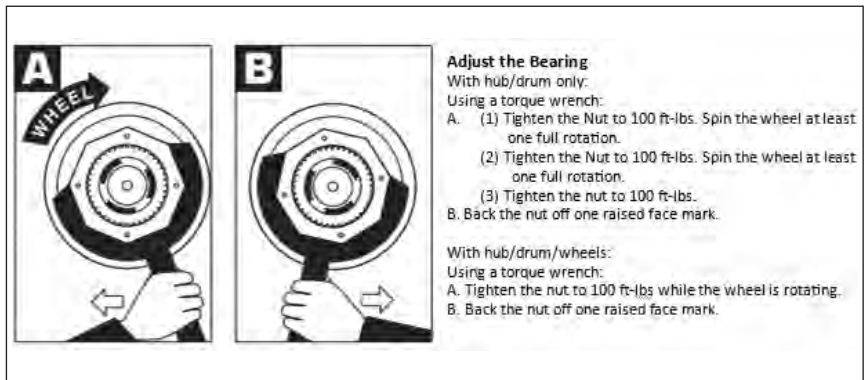

**Fig. 34 BRAKE/WHEEL END**

c. Landing gear bolts torque values (Crank type only).

|         |              |
|---------|--------------|
| 1/2 in. | 80 ft. lbs.  |
| 5/8 in. | 160 ft. lbs. |



**Fig. 35 LANDING GEAR MOUNTING BOLTS**

Weekly, 10 Days or 5000 Miles (cont'd)

- d. Retorque cast spoke wheel rim nuts if so equipped.

**Table 1 Recommended Wheel Bolt Torque (Spoke Wheels)**

| Bolt Size | Ft-lbs Torque (Dry) |
|-----------|---------------------|
| 5/8" - 11 | 150 - 175           |
| 3/4" - 10 | 210 - 260           |

**IMPORTANT**

Do not over-torque fasteners. Over-torquing can strip threads, collapse spacers or lead to other problems that cause loose fasteners. Use an accurate torque wrench when tightening fasteners.

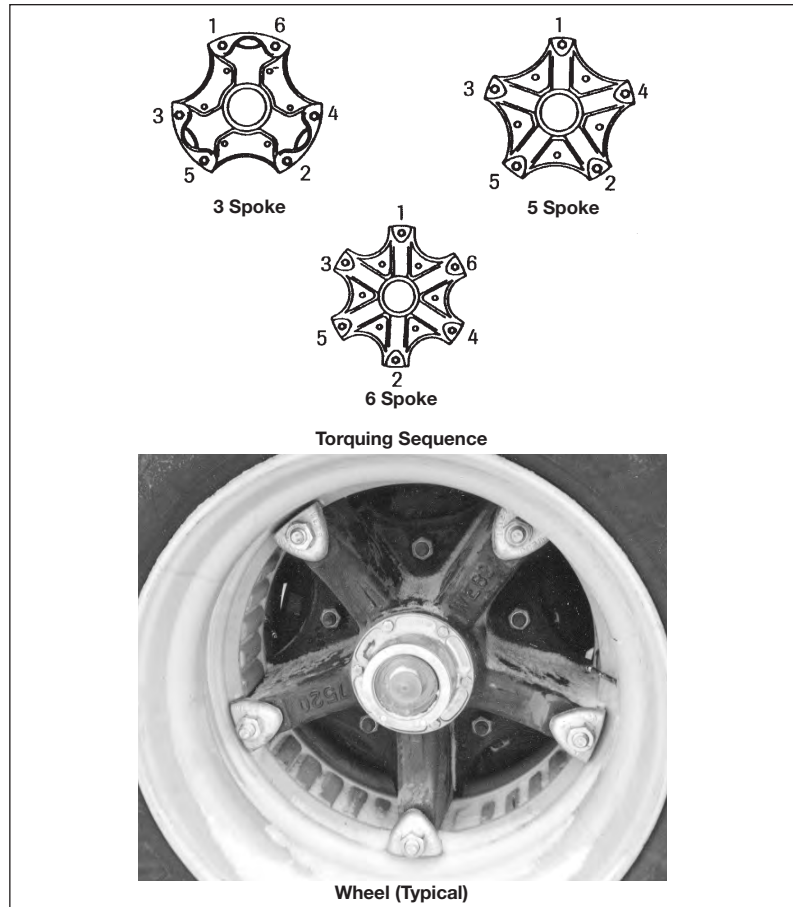

**Fig. 36 CAST WHEEL RIM NUTS**

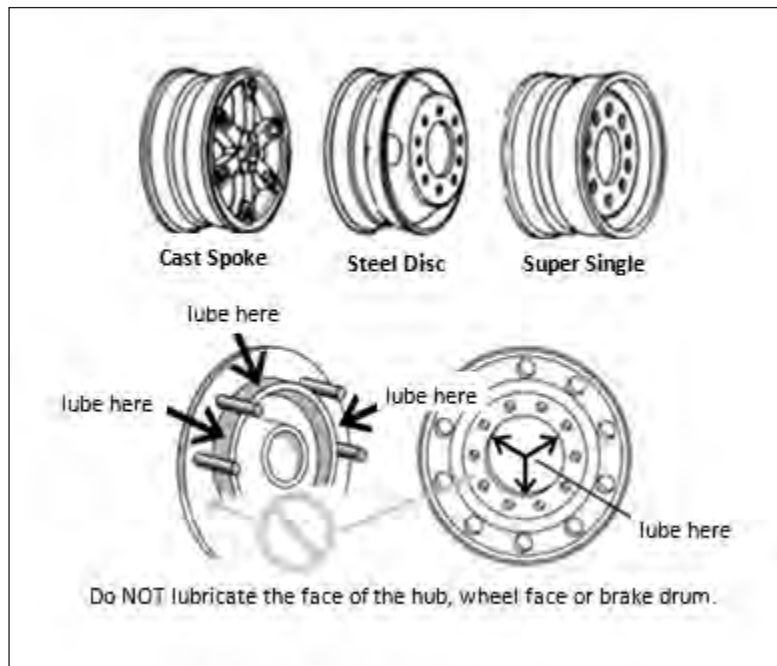

**Fig. 37 RIMS**



Weekly, 10 Days or 5000 Miles (cont'd)

- e. Retorque for stud pilot inner and outer wheel nuts if so equipped.

**Table 2 Recommended Wheel Stud Torque (Disc Wheels)**

| Stud Size   | Wheel Type      | Ft-lbs Torque (Dry) |
|-------------|-----------------|---------------------|
| 3/4" - 16   | Disc            | 450 - 500           |
| 1-1/8" - 16 | Disc            | 450 - 500           |
| 15/16 - 12  | Disc            | 750 - 900           |
| 1-5/16 - 12 | Disc            | 750 - 900           |
|             | Bud Unimount 10 | 390 - 440           |
|             | WHD-8           | 400 - 600           |

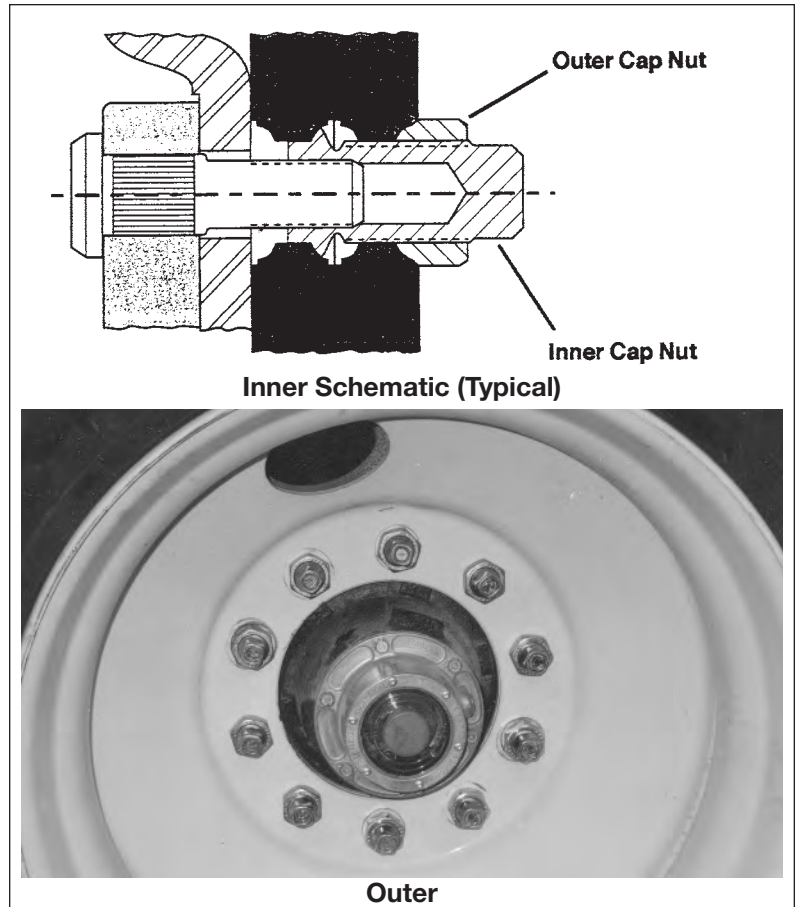

**Fig. 38 10 STUD WHEEL NUTS (Table 2)**

- f. Retorque hub piloted wheel single nuts if so equipped.

**Table 3 Recommended Wheel Stud Torque**

| Stud Size                      | Ft-lbs Torque (Oiled) |
|--------------------------------|-----------------------|
| M22 x 1.5 (33 mm or 1-1/2 Hex) | 450 - 500             |
| M20 x 1.5 (30 mm Hex)          | 280 - 330             |

**IMPORTANT**

Do not over-torque fasteners. Over-torquing can strip threads, collapse spacers or lead to other problems that cause loose fasteners. Use an accurate torque wrench when tightening fasteners.

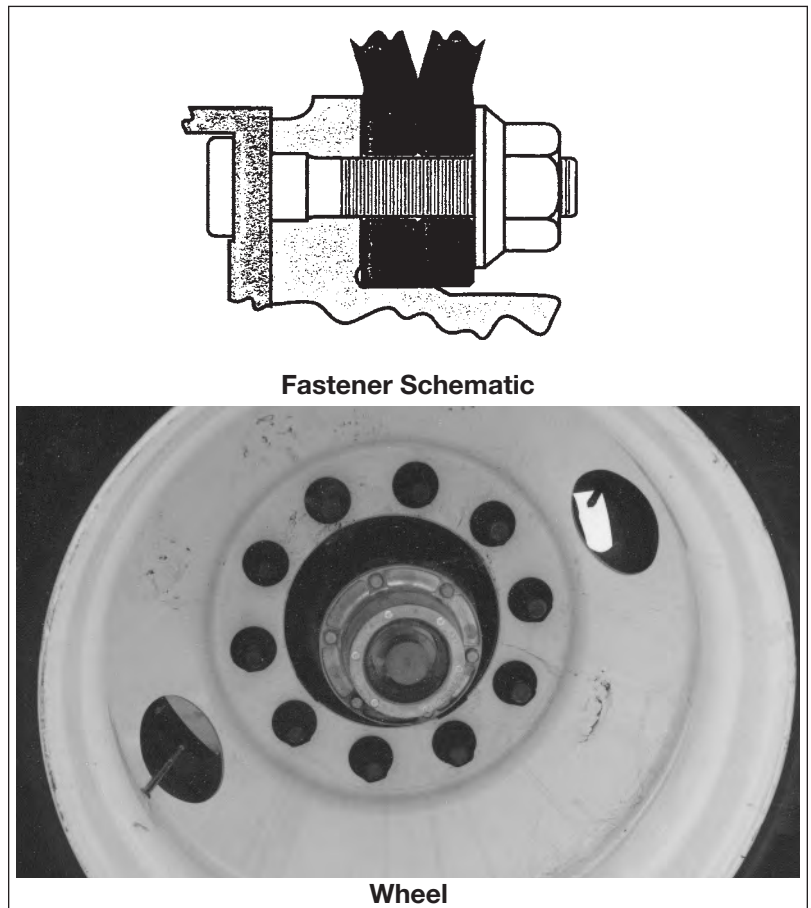

**Fig. 39 SINGLE NUTS (Table 3)**



- g. Retorque suspension system fasteners  
(Refer to charts for torque levels in  
Maintenance Section 5.2.1.

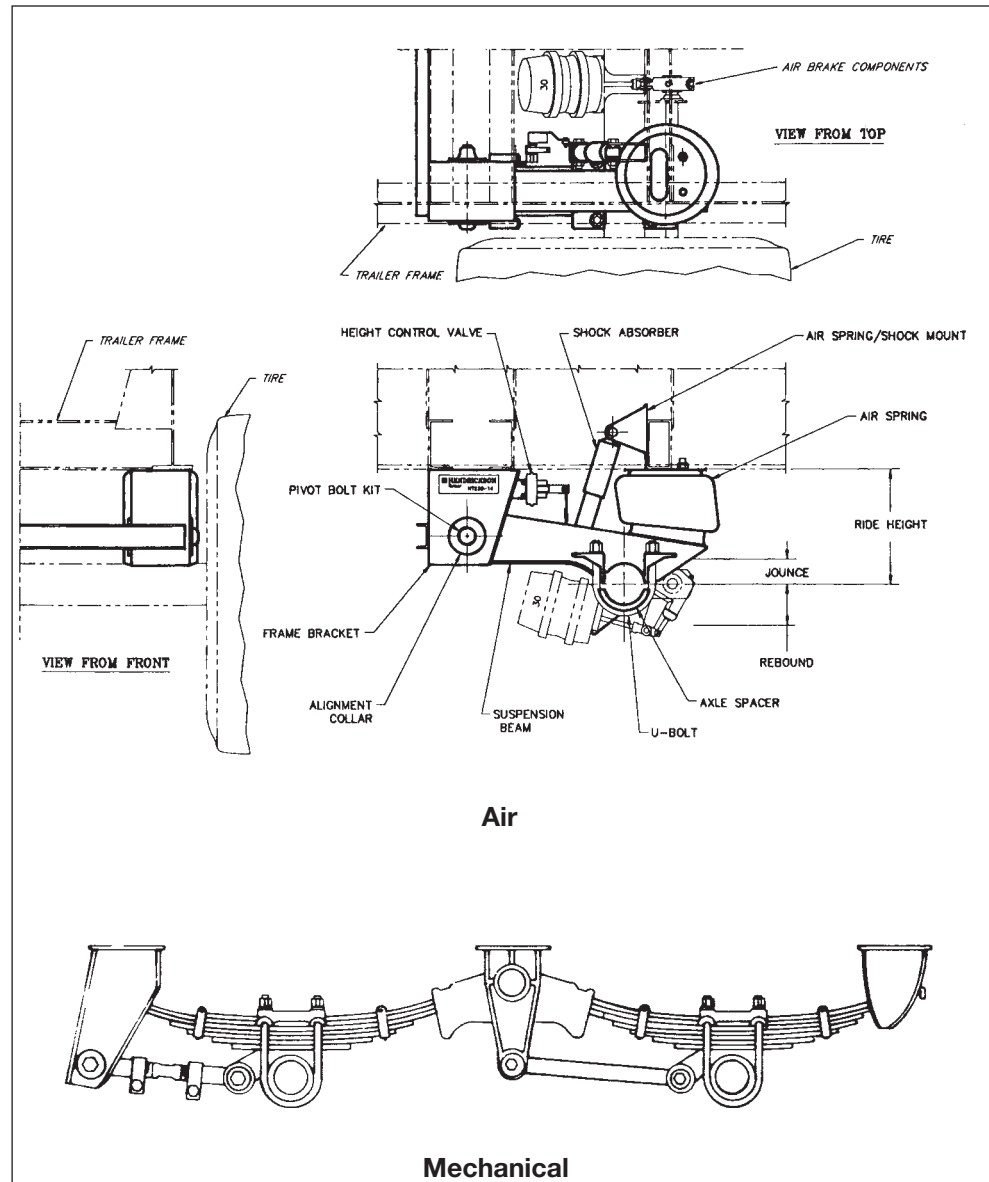

Fig. 40 SUSPENSION SYSTEM U-BOLTS

**Weekly, 10 Days or 5000 Miles (cont'd)**

- h. Retorque push block mounting bolts (if so equipped to 525 lbs.).



**Fig. 41 PUSH BLOCK MOUNTING BOLTS**

**10,000 Miles (15,000 km) or Monthly**

- 1. Grease landing gear bearings (3 locations) (crank type only).



**Right Side**



**Left Side**

**Fig. 42 LANDING GEAR**

**10,000 Miles (15,000 km) or Monthly (cont'd)**

- 2. Retorque fasteners.
  - a. Landing gear.

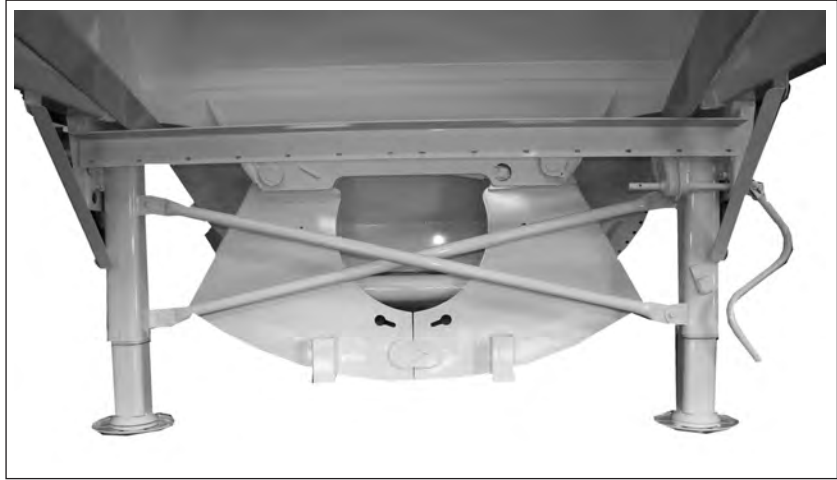

**Fig. 43 LANDING GEAR**

- b. Torque mechanical system suspension (refer to Section 5.2.12.2).

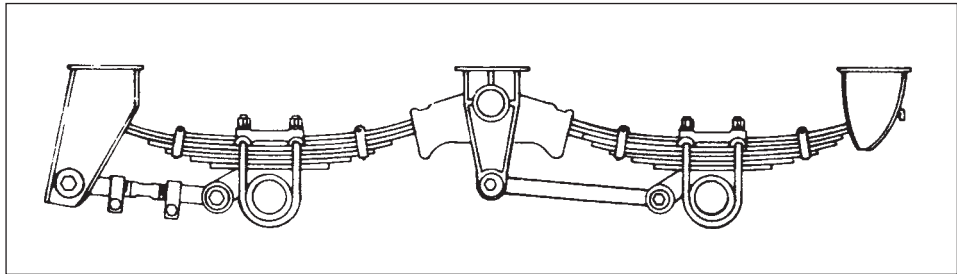

**Fig. 44 MECHANICAL SUSPENSION SYSTEM**

**25,000 Miles (40,000 km), Quarterly or Every 3 Months**

1. Check condition of wheel ends.  
Release brakes, jack up the axle and spin the wheel. Check:
  - a. Wheel bearings.
  - b. Wobble.
  - c. Rims and tires.
  - d. Brake drag.



**Fig. 45 WHEEL END**

2. Inspect frame and structure for bends, distortions or cracks.
  - a. Oscillating plate and kingpin.
  - b. Fifth wheel and mounts.
  - c. Longitudinal and transverse frames.
  - d. Compartment structure.
  - e. Discharge gate structure.
  - f. Suspension system anchorage.
  - g. Axles.
  - h. Optional Accessories
    - i. Side Boards
    - ii. Tarp



**Fig. 46 CLAM TRAILER (TYPICAL)**

3. Inspect electrical system components for:
  - a. Binding.
  - b. Rubbing/abrasion.
  - c. Looseness/dangling.
  - d. Cracks/tears in harness.
  - e. Burned out lights.
  - f. Check that front electrical connector plug anchor female trailer receptical.



**Fig. 47 ELECTRICAL (TYPICAL)**

**25,000 Miles (40,000 km), Quarterly or Every 3 Months (cont'd)**

4. Inspect air system and components for:
  - a. Perform leak-down test.
  - b. Rubbing/abrading air lines.
  - c. Cracked hoses.

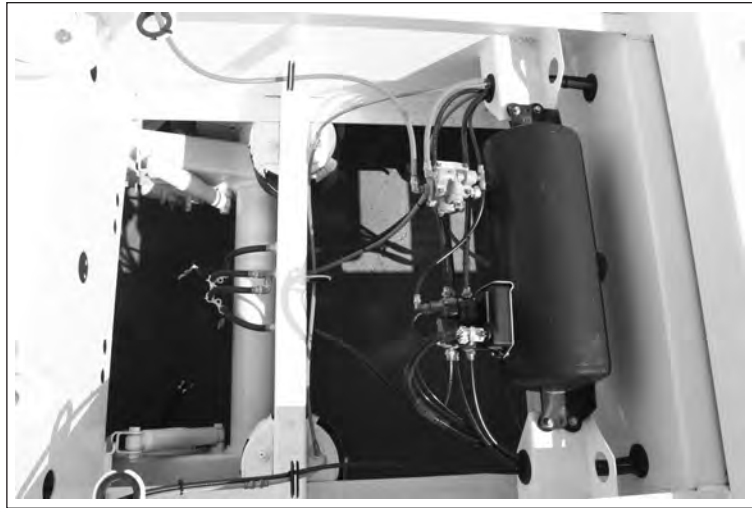

**Fig. 48 AIR SYSTEM (TYPICAL)**

5. Clean gladhand screens.

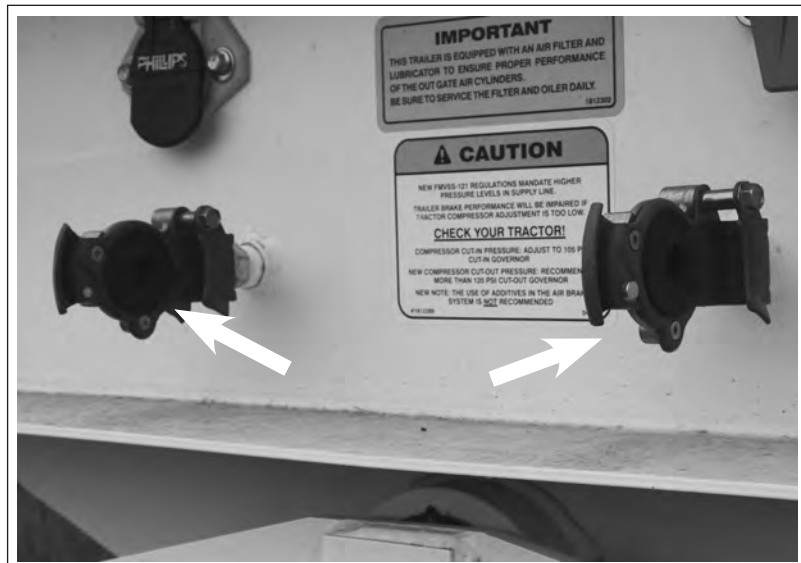

**Fig. 49 SCREENS**

6. Check brake lining thickness. Replace as required.

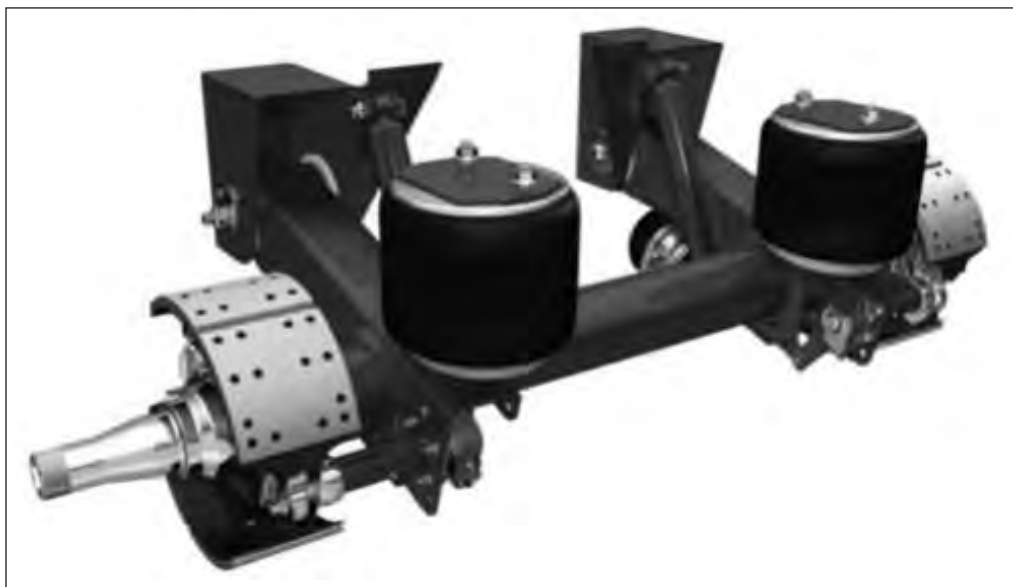

**Fig. 50 BRAKE LINING**

100,000 Miles (150,000 km) or Annually

1. Change oil in hubs.

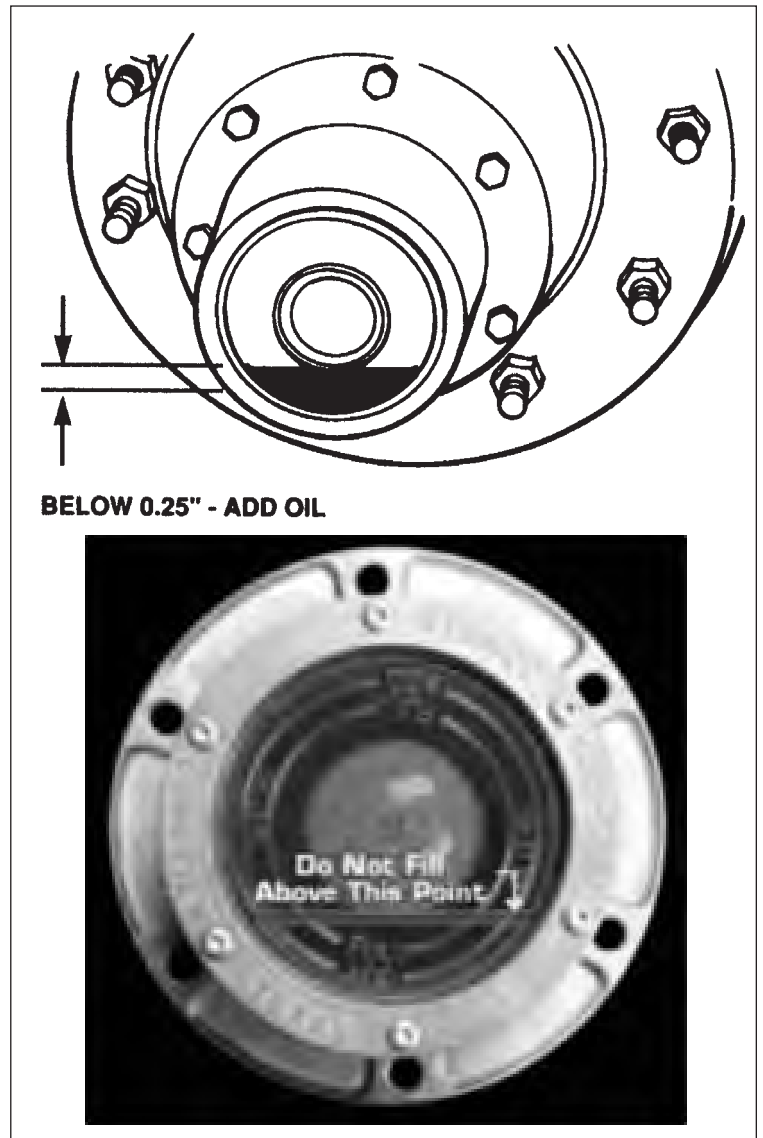

Fig. 51 HUB OIL (TYPICAL)



#### 5.1.4 SERVICE RECORD SUMMARY (LUBRICATION)

| LOCATION   | DESCRIPTION           | FREQUENCY                              | LUBRICANT           |
|--|-----------------------|--|---------------------|
| <b>Fifth wheel.<br/>Coat pivot pins<br/>and lock</b>   | Coat bearing surface. | Daily or as needed.                    | Chassis grease.*    |
| <b>Landing gear</b>  | Gearbox and screws.   | Periodic basis (weekly).               | Chassis grease.*    |
| <b>Wheels</b>  | Check oil level.      | Weekly, 10 Days or 5000 m<br>(8000 km) |                     |
|  | Bearings.             | 25,000 miles (40,000 km).              | SAE 80W90 gear oil. |
|  | Change oil.           | 100,000 miles (150,000 km).            | SAE 80W90 gear oil. |
| <b>Brakes</b>  |                       |  |                     |
| <b>Camshaft bearing</b>  | Lubricate             | 5,000 miles (8,000 km)<br>or monthly.  | Chassis grease.*    |
| <b>Slack adjuster</b>  | Lubricate             | 5,000 miles (8,000 km)<br>or monthly.  | Chassis grease.*    |
| <b>Brake shoe anchor<br/>pin bushing</b>   | Lubricate             | 30,000 miles (50,000 km) or<br>yearly. | Chassis grease.*    |
| <b>Also at brake reline.</b>   |                       | As appropriate.                        |                     |
| * Use a good quality lithium based extreme pressure grease throughout.<br>MIL-G-25013C in below -40°F. |                       |  |                     |
| <b>NOTE: Do not use excessive lubricant.</b>   |                       |  |                     |

## 5.2 PERIODIC MAINTENANCE AND ADJUSTMENTS

### MAINTENANCE SAFETY

1. Read and understand all the information in the Operator's Manual regarding maintenance, adjusting and servicing the Trailer unit.
2. Follow good shop practices:
  - Keep service area clean and dry.
  - Be sure electrical outlets and tools are properly grounded.
  - Use adequate light for the job at hand.
3. Cage spring brake chamber before disassembling.
4. Block wheels before de-activating brakes.
5. Disconnect air lines and exhaust air system completely before working on discharge gates.
6. Establish and maintain a Trailer Preventative Maintenance (TPM) program on your equipment. Some jurisdictions require this program and the maintenance of records on every commercial vehicle on the road for future reference.

Your trailer can only operate at top efficiency when it is maintained in good operating condition. The maintenance procedures are summarized from the component manufacturers instructions included with this manual. Standard industry and component procedures are required to keep your trailer in top condition. All maintenance intervals are established for normal operating conditions. In light or intermittent conditions, the servicing and maintenance intervals can be extended. In heavy, extended or severe off-highway application, reduce the intervals for servicing and maintenance to keep the equipment in good condition. When a problem is found, correct the condition before continuing.

A good maintenance program will find conditions early when they are easily and quickly corrected before they become major problems. Operating your trailer in a defective condition, can lead to serious mechanical problems or can create safety hazards for the driver, bystanders or other operators.

### 5.2.1 TORQUE SPECIFICATION SUMMARY

Table 4 Recommended Torque Specifications

#### 1. Oscillating Plate

| Oscillating Plate                   |           |         |
|-------------------------------------|-----------|---------|
| Oscillating 5th Wheel Bushing Bolts | 3/4" lbs. | 250 ft. |

**RAR-240 Monopivot**

**RIDEWELL SUSPENSION TORQUE CHART**

| ITEM                | SIZE         | TORQUE  |       |
|---------------------|--------------|---------|-------|
|                     |              | (FT-LB) | (N-m) |
| Pivot Bolt/Nut      | 1 1/4" - 7NC | 1,000   | 1,350 |
| Shock Bolt/Nut      | 3/4" - 10NC  | 200     | 270   |
| Air Spring Bolt/Nut | 1/2" - 13NC  | 25      | 35    |
| Air Spring Bolt/Nut | 3/4" - 16NF  | 50      | 70    |

After suspension has been in operation for approximately 5,000 miles (10,000 km), all fasteners must be re-tightened to specified torque. Repeat every 50,000 miles (80,000 km).

**DO NOT OVER-TORQUE!**

#### 2. Air Ride Suspension

TRAILER SUSPENSION BOLT TORQUE VALUES<sup>1</sup>

| COMPONENT DESCRIPTION  | FT-LBS <sup>1</sup> | N-m          |
|--|---------------------|--------------|
| QUIK-ALIGN® Pivot Connection   | 505 to 695          | 685 to 807   |
| Welded Pivot Connection (1 1/2 inches)   | 750 to 825          | 1017 to 1119 |
| U-Bolts (HT Series)  | 475 to 525          | 644 to 712   |
| Shock Bolts  | 210 to 235          | 285 to 319   |
| Upper Air Spring Nuts (3/4 inch)   | 80 to 100           | 108 to 136   |
| Upper Air Spring Nuts (1/2 inch)   | 40 to 50            | 54 to 68     |
| Lower Air Spring Bolts (HT Series, AAEDT 30K, AAEDL 30K and HRRNT 40K / HRRNT 60K) | 40 to 50            | 54 to 68     |
| Lower Air Spring Nut (INTRAAK® and VANTRAAK®)                                      | 55 to 60            | 75 to 81     |
| Brake Chamber Mounting Nut (INTRAAK)   | 100 to 110          | 136 to 149   |
| S-Cam Support Bearing Mounting Nut (INTRAAK)                                       | 35 to 45            | 47 to 61     |
| Hubcap Mounting Bolts  | 12 to 18            | 16 to 24     |
| Body Rail Clip   | 65 to 75            | 88 to 102    |
| Lift Mechanism Air Spring, Actuator (3/4 inch)                                     | 45 to 55            | 61 to 75     |
| Lift Mechanism Air Spring, Actuator (3/8 inch)                                     | 15 to 20            | 20 to 27     |

| COMPONENT DESCRIPTION              | IN-LBS    | N-m        |
|------------------------------------|-----------|------------|
| ABS Bracket Bolt and Nut (INTRAAK) | 75 to 100 | 8 to 11    |
| Disc Brake Dust Shield Clamp       | 50 to 70  | 5.6 to 7.9 |
| Drum Brake Dust Shield Clamp       | 90 to 125 | 10 to 14   |
| Height Control Valve Mounting      | 60 to 80  | 7 to 9     |

<sup>1</sup>Torque values in this table are for fasteners as supplied by Hendrickson Trailer Suspension Systems.

**IMPORTANT: DO NOT APPLY ADDITIONAL LUBRICANT TO FASTENER THREADS. DOING SO WILL REDUCE THE FRICTION BETWEEN FASTENER COMPONENTS, WHICH CAN LEAD TO OVERTIGHTENING, UNPREDICTABLE CLAMP LOADS AND UNRELIABLE FASTENER CONNECTIONS**

**RIDEWELL SUSPENSIONS RAR-260** 199002 RevA

| ITEM                    | SIZE      | TORQUE                    |
|-------------------------|-----------|---------------------------|
| Pivot Bolt (Shear-Type) | 7/8"-9NC  | See Below                 |
| Pivot Nut (Lock Nut)    |           |                           |
| Shock Bolt/Nut          | 3/4"-10NC | 200-230 ft-lb 271-312 N-m |
| Air Spring Nut - Upper  | 3/4"-16NF | 45-50 ft-lb 61-68 N-m     |
| Air Spring Nut - Lower  | 1/2"-13NC | 45-50 ft-lb 61-68 N-m     |
| Air Spring Bolt - Lower | 1/2"-13NC | 20-25 ft-lb 27-34 N-m     |

Tighten pivot bolt using a 1" drive impact wrench and RW #6100054 E-20 Torx® socket (or equivalent) until Torx® head shears off.  
Suspension fasteners to be re-torqued initially at 6,000 miles and at 50,000 mile increments thereafter. Do not re-torque pivot fasteners.  
See service manual for details.  
Ridewell Suspensions • Springfield, MO USA • 800.641.4122 • www.ridewellcorp.com

**Table 4 Recommended Torque Specifications (cont'd)**

**3. Mechanical Suspension**

**REYCO 21B SPRING RIDE SUSPENSION**

| TORQUE REQUIREMENTS   |            |            |
|---|------------|------------|
| <i>(cast hangers)</i>   |            |            |
| 1. Tighten 3/4" or 7/8" U-bolt nuts                               | 300-325 FP | 410-440 Nm |
| 2. Tighten 1" torque arm end nuts                                 | 140-160 FP | 190-220 Nm |
| 3. Tighten 5/8" torque arm clamp nuts                             | 125-150 FP | 170-205 Nm |
| 4. Tighten 1" equalizer capscrews                                 | 400-450 FP | 540-610 Nm |
| 5. Tighten 1/2" spring retainer nuts                              | 70-80 FP   | 95-110 Nm  |
| <i>(I-beam hangers)</i>   |            |            |
| 1. Tighten 3/4" or 7/8" U-bolt nuts—steel springs                 | 300-325 FP | 410-440 Nm |
| 2. Tighten 3/4" or 7/8" U-bolt nuts (composite springs)           | 250 FP     | 340 Nm     |
| 3. Tighten 11/4" equalizer shaft fastener nuts                    | 575-625 FP | 780-850 Nm |
| 4. Tighten 21/2" equalizer shaft fastener nuts (FWWB 54"-65 1/2") | 300-325 FP | 410-440 Nm |
| 5. Tighten 11/2" equalizer shaft fastener nuts (FWWB 72"-109")    | 200-225 FP | 270-305 Nm |
| 6. Tighten 1" torque arm bolt nuts                                | 140-160 FP | 190-220 Nm |
| 7. Tighten 5/8" torque arm clamp nuts                             | 125-150 FP | 170-200 Nm |
| 8. Tighten 3/4" torque arm clamp nuts                             | 175-200 FP | 240-270 Nm |
| 9. Tighten 1/2" spring retainer nuts                              | 70-80 FP   | 95-110 Nm  |

Ft lb = Foot - Pounds; Nm = Newton - Meters

**HUTCH SPRING RIDE SUSPENSION**

**WARNING**

**SAFETY ALERT!** (1) FOLLOW ALL TORQUE REQUIREMENTS. (2) DO NOT USE ANY COMPONENT WITH VISIBLY WORN OR DAMAGED THREADS. FAILURE TO FOLLOW THESE SAFETY ALERTS CAN LEAD TO LOSS OF VEHICLE CONTROL, PROPERTY DAMAGE, SERIOUS PERSONAL INJURY OR DEATH.

**Hutchens Suspension Torque Requirements**  
9600-9700 Series ( Decal Part Number 16086-01 Rev. J )

After an initial break in period, approximately 1000 miles, and at least every 4 months periodically thereafter, ALL bolts and nuts should be checked to insure that recommended torque values are being maintained.  
Oiled torque values listed are for new fasteners with lubricated threads. It is recommended that new installations be performed with oiled fasteners. For dry threads which have been in service, use the higher torque values which are noted below.

|  | OILED     | DRY       |
|--|-----------|-----------|
| 1 1/8-7 ( 9600 / 9700 Rocker Bolt )            | 590 lb-ft | 790 lb-ft |
| 1-14 or 1-8 ( 9700 Radius Rod Bolt )           | 540 lb-ft | 720 lb-ft |
| 7/8-14 ( Axle U-Bolts & 9600 Radius Rod Bolt ) | 350 lb-ft | 470 lb-ft |
| 3/4-16 ( Axle U-Bolts )                        | 310 lb-ft | 420 lb-ft |
| 5/8-18 ( Radius Rod Clamp Bolt )               | 130 lb-ft | 170 lb-ft |
| 5/8-18 ( Spring Retainer Bolt )                | 35 lb-ft  | 50 lb-ft  |

**HUTCH** Hutchens Industries, Inc., P.O. Box 1427, Springfield, Missouri 65801-1427 Toll Free 1 (800) 654-8824

**4. Wheel End Components**

| Description  | Torque Range   |           | Fastener Size                                     |
|--|--|-----------|---|
|  | N.m  | (lb-ft)   |   |
| 1. Hub-cap bolts   | 10-15  | 13-20     | 5/16"   |
| 2. Hub fill plug   | 15-20  | 20-27     | 3/8"  |
| 3. Adjustment nut - manual bearing adjustment (double nut) | Tighten to 100, loosen, tighten to 50, loosen 1/4 turn | 136<br>68 | Size depends on axle model and adjustment method. |
| 4. Jam nut - manual bearing adjustment                     | 250-300  | 340-408   |   |
| 5. Brake mounting bolt                                     | 130-165  | 177-224   | 5/8"  |
| 6. Two-piece dust shield bolts (shown)                     |  |           |   |
| • Forged spider  | 15-20  | 20-27     | 3/8"  |
| 7. Bolt-on bushing bolts                                   | 25-35  | 34-48     | 3/8"  |
| 8. Cam bushing bolts                                       | 25-35  | 34-48     | 3/8"  |
| 9. Air chamber nuts  | 80-125   | 109-170   | 5/8"  |

**5. Wheel Nut**

| Stud Size   | Wheel Type            | Ft-lbs Torque (Dry) | Bolt Size | Ft-lbs Torque (Dry) |
|-------------|-----------------------|---------------------|-----------|---------------------|
| 3/4" - 16   | Disc                  | 450 - 500           | 5/8" - 11 | 150 - 175           |
| 1-1/8" - 16 | Disc                  | 450 - 500           | 3/4" - 10 | 210 - 260           |
|             | Bud Unimount 10 WHD-8 | 390 - 440           |           |                     |
|             |                       | 400 - 600           |           |                     |

## 5.2.2 KINGPIN AND OSCILLATING FIFTH WHEEL PLATE

The kingpin at the front of the trailer is the structural component used to transmit accelerating and decelerating loads into the trailer frame. It must be in good condition to perform as required.

Visually inspect the kingpin as part of the pre-trip inspection, at 5,000 miles (8,000 km) or weekly and annually as part of your normal preventative maintenance program. Be sure the kingpin does not have excessive wear, looseness, chipped out areas, cracks or bent mounting frame. If any kingpin shows such defects, it should be replaced immediately.

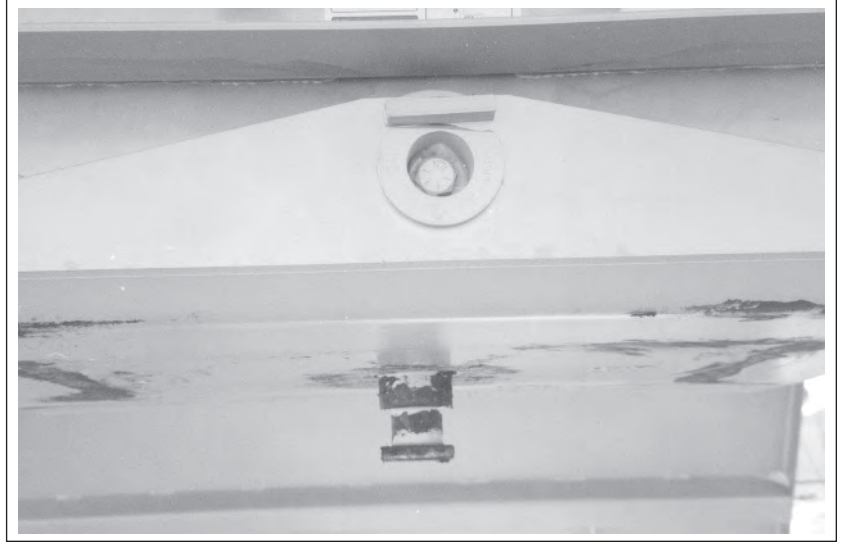

Fig. 52 KINGPIN

Visually inspect the frame and structure of the oscillating plate for bends, cracks or distortions as part of the pre-trip inspection procedure. Thoroughly inspect the structural integrity of the assembly every 25,000 miles (40,000 km) or every three months as part of your preventative maintenance program. Replace the entire assembly if any structural defects are found.

Retorque the oscillating plate anchor bolts to 275-325 ft/lbs after first 500 miles and every 10,000 miles (15,000 km) thereafter. Loose anchor bolts will reduce or eliminate the effectiveness of the rubber bushings and can lead to premature failure. Always attach the torque wrench to the Stover lock nut when tightening. Inaccurate readings are obtained when tightening the bolt head.

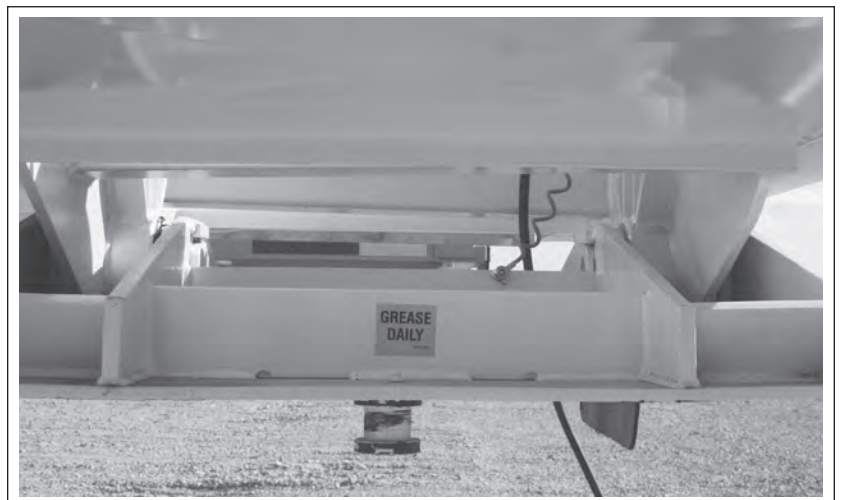

Fig. 53 ANCHOR BOLTS

### IMPORTANT

If a lube plate is used in your operation, make sure to check the kingpin length. The kingpin must be sized to compensate for the thickness of the lube plate. Otherwise, the kingpin will be too short. If the kingpin length is improper, the kingpin should be replaced.

### 5.2.3 FIFTH WHEEL

A fifth wheel system is used on the rear of the front B train unit and on the towing tractor to secure the kingpin and carry the weight of the attached trailer. It must be maintained in good condition to perform as intended.

Visually inspect the fifth wheel as part of the pre-trip inspection to check for cracks, bends, chips or distortions of the frame and upper plate.

#### NOTE

Use a high-pressure washer or steam cleaner to remove all the dirt and grease from the fifth wheel assembly prior to each weekly inspection. Apply a fresh coat of grease to the fifth wheel assembly prior to hooking-up the trailer.



Fig. 54 FIFTH WHEEL

Clean the assembly every 5,000 miles (8,000 km) or weekly and annually to perform a thorough inspection. Check the frame and upper plate for cracks, bends, chips or distortions.

When the components are clean, check that the lock closes completely around the kingpin.

To adjust the lock:

1. Obtain a Holland kingpin lock tester and place in the throat of the lock. Close the lock.
2. The jaws should be snug around the tester but not binding.
3. Use the adjusting nut on the front edge of the fifth wheel to set the clearance of the jaws.
4. Use a light oil to lubricate all moving parts prior to returning to service.

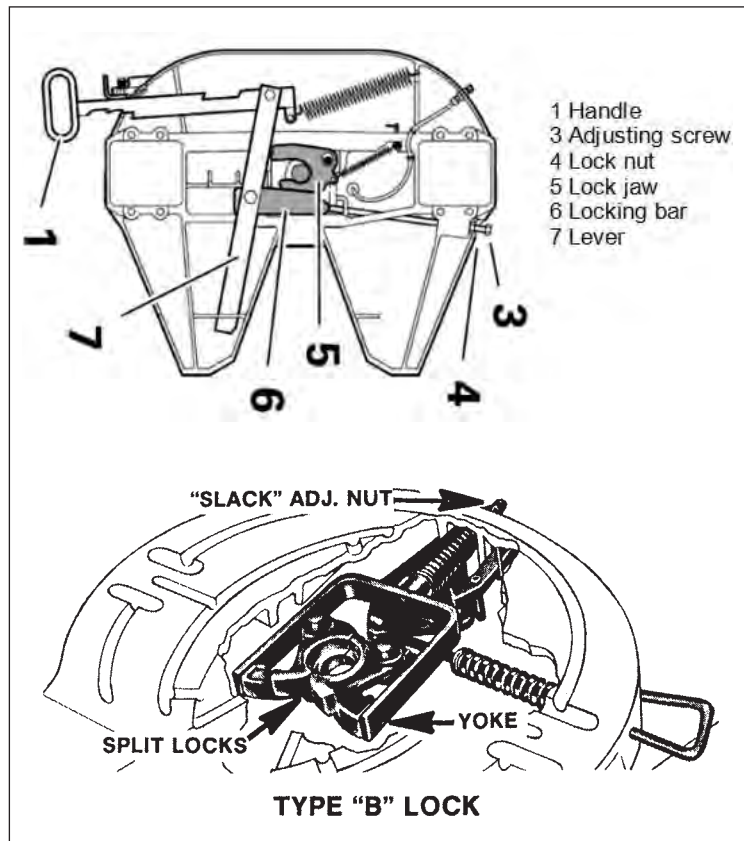

Fig. 55 KINGPIN LOCK



## 5.2.4 AXLE ALIGNMENT

A standard axle is used as the main transverse structural member to transmit loads between the trailer frame and the surface contacting components. All running gear components are attached to or part of the axle assembly.

Although there is very little that can go wrong with the axle itself, loose, bent or damaged attaching components can cause the axle to go out of alignment. This misalignment will be found during the regularly scheduled 25,000 mile inspection. However, axle misalignment shows itself most commonly by accelerated tire wear and dogtracking by the trailer. Visually check the tire wear when checking air pressure. The driver should identify these handling characteristics to service personnel or correction.

To check axle alignment, follow this procedure:

1. Select a working area that is level, with a compacted surface and is large enough to provide access from all sides.
2. Move the trailer forward and backward several times to remove any binding from the components.
3. Stop the trailer when moving in the forward direction without using trailer brakes. This will give the components a forward bias with no binding.
4. Unhook the trailer and support on the landing gear at the normal highway height and parallel to the ground.
5. Install a commercially available axle extender on each axle or remove the wheels to prevent any components from interfering with the measurements.



## 5.2.4 AXLE ALIGNMENT (cont'd)

6. Attach an S hook to a steel tape and measure the distance between the kingpin and the end of each axle. Dimensions A and B should be equal within  $\pm 1/8$  inch (0.125 in) (3.1 mm).
7. Adjust the suspension mounting system as required to set dimension A and B within  $1/8$  inch (0.125 in) (3.1 mm). Refer to suspension system instruction brochure for detailed adjustment procedure.

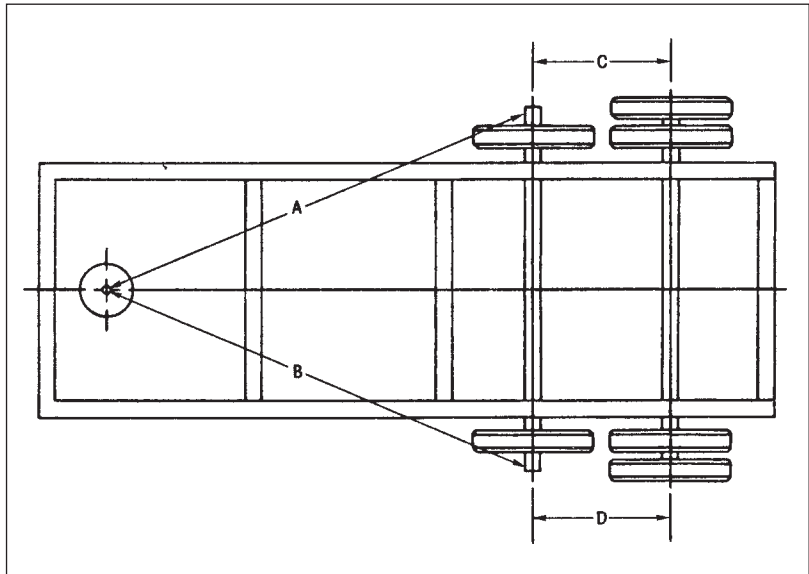

Fig. 56 AXLE DIMENSIONS

8. Use a trammel bar to measure the road and curbside dimensions between the first and second axles. Dimensions C and D should be within  $1/16$  inch (0.0625 in) (1.6 mm).

### IMPORTANT

It may be necessary to build a large trammel bar to measure and clear the discharge gates.

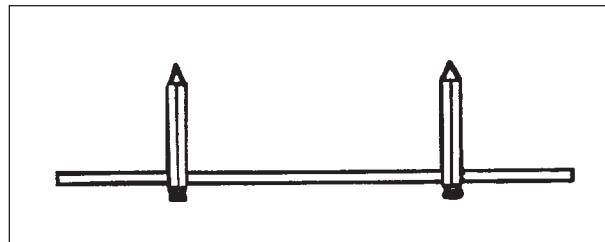

Fig. 57 TRAMMEL BAR

9. Set the suspension system as required to set this dimension to its recommended tolerance.
10. Repeat measuring and adjustment procedure on the third axle if so equipped.
11. Tighten all fasteners to their specified torque. Do not allow any suspension system or running gear fasteners to loosen.

### IMPORTANT

Always use a torque wrench when tightening fasteners. The correct torque on a fastener provides the proper clamping force on the adjacent components and they will perform as expected.

12. The front axle must be aligned to the kingpin with second and third axles adjusted to the front axle.
13. Always check axle alignment after repairing the suspension system.

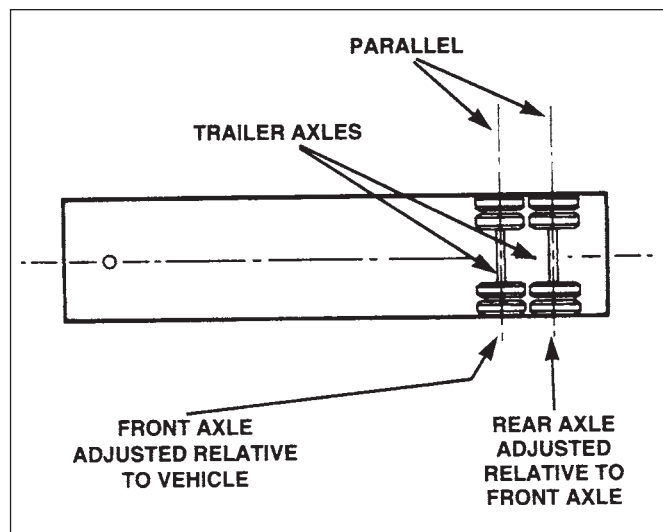

Fig. 58 ALIGNED

## 5.2.5 WHEEL HUBS/BEARINGS

All axles use an oil bath design for lubricating wheel bearings. It is a virtual zero maintenance system providing that the oil remains in the hub.

Visually check the hub every day for leaks when checking tire pressure during pre-trip, daily, refueling, or rest stop inspections. If oil leaks are detected on any hub, repair the leak and refill the hub before proceeding.

### A. Oil Leaks:

Visually inspect the hub for leaks every time the tire pressures are checked. Leaks will normally be visible as dust collects on the escaping oil. Stop and correct the leak immediately to prevent running the hub low on oil. Running low or without oil will quickly overheat the hub and cause the bearings to seize. Change the oil in the hub when installing new seals to correct a leak.

### B. Oil Level:

1. Check the oil level in each wheel hub every 5,000 miles (8,000 km) or weekly and whenever an oil leak is found. Clean the end plate of the hub to remove the dust, dirt or mud build-up.

The oil should be visible to the top of the outer concentric circle of the end cap. Add oil as required through the fill plug in the hub. Always use clean oil and prevent contaminants from entering the hub when adding or changing oil.

2. Change the oil every 100,000 miles (160,000 km), annually or whenever the axle nuts are retorqued or the brakes are relined. The hub cavities must be opened when retorquing axle nuts or relining the brakes and changing oil should be done as part of the procedure.

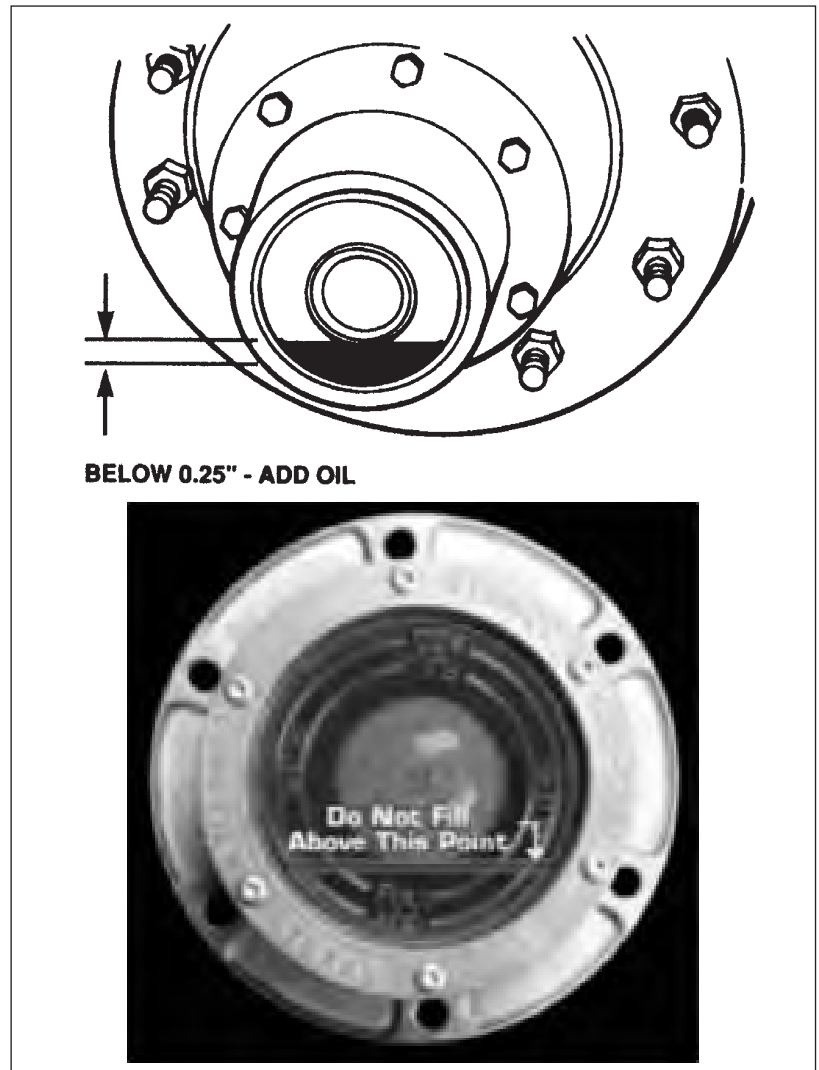

Fig. 59 OIL LEVEL

## 5.2.5 WHEEL HUBS/BEARINGS (cont'd)

### C. Wheel Bearings:

Wheel bearings carry and transmit the load between the wheels and the axles. In addition to proper lubrication, the bearings must have the recommended pre-load to perform as expected. Bearing pre-load is set and controlled by the torque of the wheel nuts on the end of each spindle. Each hub must seat securely on its bearings to prevent wobble or slop in the system. Turning the wheel or wobbling it indicates the condition and tightness of the hub/bearing assembly.

#### 1. Turning/Wobble:

- a. Park the trailer on a level, hard surface and release the brakes.
- b. Place chocks in front of and behind each wheel.
- c. Jack each axle up until the tire clears the ground.
- d. Support the axle on a safety stand to prevent slipping or tipping.
- e. Turning the wheel slowly to check the condition of the bearings and to determine if the brakes are dragging.



Fig. 60 WHEELS

- f. **Dragging Brakes:** Can be felt as a steady drag on the turning of the wheel or at the same position or arc of the rotation. Adjust the brakes to eliminate the drag before resuming work.
- g. **Bearing Condition:** Can be felt as the wheel turns. Bearings in good condition turn easily and smoothly. Bearings in poor or bad condition can be felt through the wheels as scraping, grinding, dragging or bumps. Replace bearings before resuming work.

- h. **Wobble:** Grasp each side of the wheel or tire and wiggle the wheel and assembly. If the wheel or hub wobble on the spindle, the bearings have lost their pre-load and the wheel bearing adjusting nut requires tightening.

#### NOTE

If the bearings are not in good condition, replace them before setting the pre-load.

**C. Wheel Bearings (cont'd):**

**2. Bearing Pre-Load:**

- a. Place a pan under the hub drain plug.
- b. Remove the drain plug from the hub and drain the oil.
- c. Remove the hub end plate and lay to the side.
- d. Remove the set screw from the jam nut.
- e. Remove the jam nut and perforated lock washer from the spindle.
- f. Use a torque wrench to tighten the adjusting nut 100 ft-lbs. (136 N.m) while rotating the wheel assembly in both directions.
- g. Back the adjusting nut off to zero torque.
- h. Retorque the adjusting nut again to 50 ft-lbs (68 N.m) of torque while rotating the wheel assembly in both directions.
- i. Loosen the nut 1/4 turn.
- j. Install the perforated lock washer. Be sure the adjusting nut pin aligns with the hole in the lock washer. Turn washer over and/or adjusting parts as required.
- k. Install jam nut and tighten to 250-300 ft-lbs. (340-408 N.m).

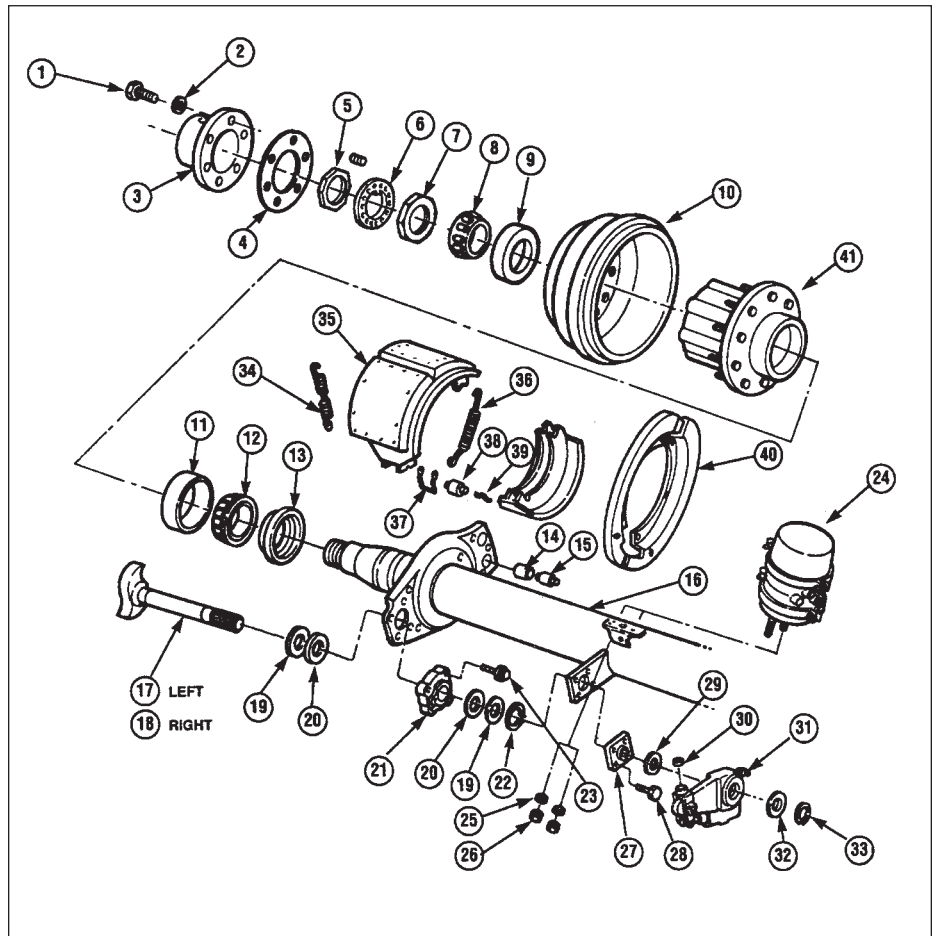

| ITEM | DESCRIPTION                 | ITEM | DESCRIPTION                   |
|------|-----------------------------|------|-------------------------------|
| 1    | Capscrew                    | 22   | Snap ring                     |
| 2    | Lockwasher                  | 23   | Capscrew                      |
| 3    | Hub cap                     | 24   | Air chamber                   |
| 4    | Gasket                      | 25   | Lockwasher                    |
| 5    | Wheel bearing jam nut       | 26   | Locknut                       |
| 6    | Lockwasher                  | 27   | Camshaft busing assembly      |
| 7    | Wheel bearing adjusting nut | 28   | Capscrew                      |
| 8    | Cone outer wheel bearing    | 29   | Washer slack adjuster         |
| 9    | Cup - bearing outer         | 30   | Locknut - slack adjuster      |
| 10   | Brake drum                  | 31   | Automatic slack adjuster      |
| 11   | Cup - bearing inner         | 32   | Washer slack adjuster         |
| 12   | Cone - bearing inner        | 33   | Snap ring slack adjuster      |
| 13   | Seal wheel-bearing          | 34   | Spring - brake shoe return    |
| 14   | Bushing anchor pin          | 35   | Brake show and lining assy.   |
| 15   | Pin anchor                  | 36   | Spring - brake shoe retaining |
| 16   | Beam axle                   | 37   | Retainer - brake shoe roller  |
| 17   | Camshaft (left)             | 38   | Roller - brake shoe           |
| 18   | Camshaft (right)            | 39   | Pin - shoe return spring      |
| 19   | Washer                      | 40   | Dust shield                   |
| 20   | Seal                        | 41   | Hub                           |
| 21   | Bushing                     |      |                               |

**Fig. 61 SPINDLE COMPONENTS**

- I. Check bearing end play by:
  - i. Attaching a magnetic base dial gauge indicator to the end of the spindle.
  - ii. Push the wheel in while rotating the wheel slightly until the dial gauge reading doesn't change.
  - iii. Zero dial gauge.
  - iv. Pull wheel assembly out while rotating wheel slightly until dial reading doesn't change.
  - v. Dial indicator will read bearing end play.
  - vi. If end play does not register between 0.001-0.010 inches (0.025-0.25 mm), replace bearings or hub components until it does.
- m. Install a new gasket on hub face cap.
- n. Install hub face cap and tighten mounting cap screws to their specified torque.
- o. Add the specified amount of oil to the hub and secure fill plug. Check for leaks. Correct leaks before resuming operation.
- p. Remove safety stand from under axle and lower wheel to the ground.
- q. Repeat checks on all other axles.

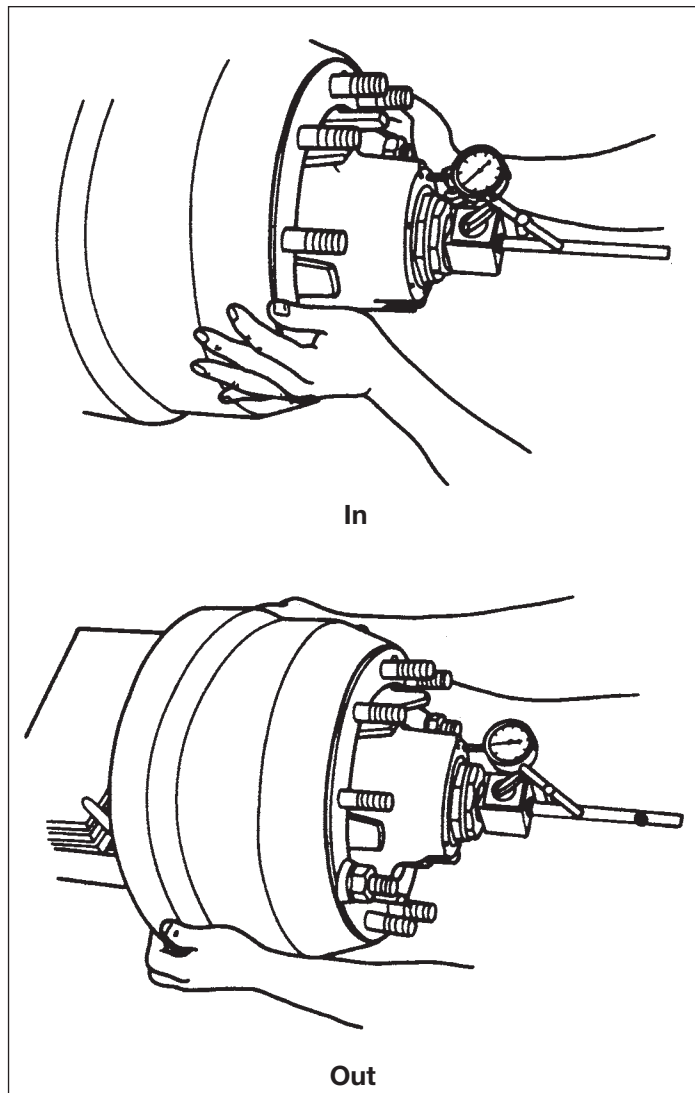

**Fig. 62 DIAL INDICATOR**

## 5.2.6 WHEELS

A variety of steel or aluminum wheels can be used on the trailer depending on customer preference or application requirements. Wheels must be maintained in good condition and all fasteners tightened to their specified torque level to obtain the expected life and performance.

Loose fasteners are the most common cause of wheel problems on a trailer. Always retorque the wheel fasteners per the break-in schedule of 100, 500, 1500 and 5,000 miles (160, 800, 2500 and 8000 km) when the unit is new and after a wheel has been removed. Always use an accurate or calibrated torque wrench when tightening fasteners. A loose fastener is defined as one that is not tightened to its specified torque. A loose fastener does not provide the required clamping, anchoring or holding forces to stabilize the adjacent components. Insufficient clamping forces can lead to flexing, bending, cracking, hole elongation or other component deterioration that cause failures and/or accidents. Always keep fasteners tightened to their specified torque. Over-torquing can overload certain components, causing compression cracks and strip nuts or studs. Over-torquing fasteners can be as detrimental as under-torquing. Always tighten fasteners to their specified torque.

Use an accurate torque wrench to retorque wheel fasteners every 10,000 miles (15,000 km) or monthly whichever comes first. Always retorque wheels per the break-in schedule whenever a wheel is removed and remounted.

Always follow the recommended mounting procedure when installing wheels to the trailer.

### 1. Disc Wheels (Stud Pilot Style):

- Mount single or inner dual wheel on hub. Be careful not to damage the threads on any of the studs.
- Snug the nuts up in the alternating sequence shown to center it on the hub and insure an even contact between the wheel and hub.
- Tighten nuts to their specified torque using the same alternating sequence.

#### IMPORTANT

Left-hand threads are used on the left side of the vehicle. Right-hand threads on right.

- Mount outer dual. Do not damage the threads when sliding the wheel over the studs.
- Snug up the nuts in the alternating sequence shown to center it on the hub and to provide even contact.
- Tighten the outer wheel nuts to their specified torque.

#### IMPORTANT

When retorquing inner nuts of double nut design, always back off outer nut several turns, then retorque them.

**Table 5 Recommended Wheel Stud Torque (Disc Wheels)**

| Stud Size  | Wheel Type      | Ft-lbs Torque (Dry) |
|------------|-----------------|---------------------|
| 3/4"-16    | Disc            | 450 - 500           |
| 1-1/8"-16  | Disc            | 450 - 500           |
| 15/16"-12  | Disc            | 750 - 900           |
| 1-5/16"-12 | Disc            | 750 - 900           |
|            | Bud Unimount 10 | 390 - 440           |
|            | WHD-8           | 400 - 600           |



**Fig. 63 NUT TORQUE SEQUENCE**



**2. Hub Piloted Wheels:**

- a. Mount inner wheel on the hub.
- b. Slide on the hub guide until the wheel is snug against the hub. Be careful not to damage the threads on any of the studs.
- c. Mount outer dual wheel on the hub and snug up against the inner wheel.

**NOTE**

Add a drop or 2 of oil on the end of the bolt, threads and the nuts and flanges.

- d. Install nuts and tighten in alternate sequence shown.

**Table 6 Recommended Wheel Bolt Torque**

| Stud Size                         | Ft-lbs Torque (Oiled) |
|-----------------------------------|-----------------------|
| M22 x 1.5<br>(33 mm or 1-1/2 Hex) | 450 - 500             |
| M20 x 1.5<br>(30 mm Hex)          | 280 - 330             |

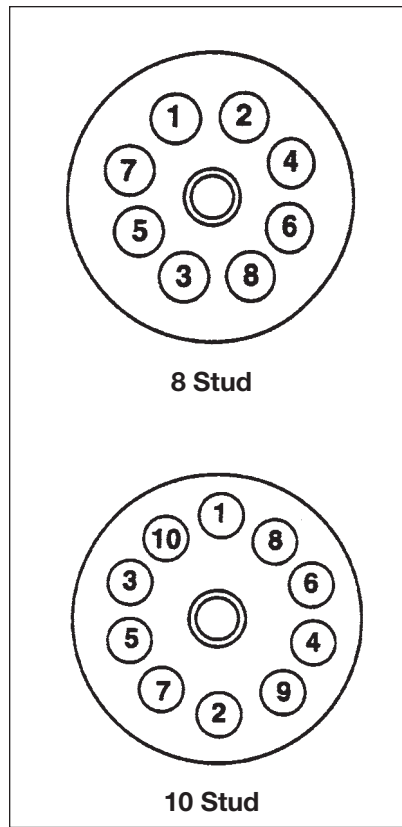

**Fig. 64 HUB PILOTED**

**3. Rim/Wheel (Cast Spoke):**

- a. Inspect and clean all the parts. Replace any damaged components.
- b. Place rims and spacer band on wheel. Be sure to space valve stem between spokes.
- c. Secure clamps evenly in position.
- d. Snug up the nuts in the alternating sequence shown to allow the inside rim to seat itself on the mounting bevel and avoid wheel wobble.
- e. Tighten the nuts evenly in small increments in the shown alternating sequence until all nuts are tightened to their specified torque.

**Table 7 Recommended Wheel Bolt Torque (Spoke Wheels)**

| Bolt Size | Ft-lbs Torque (Dry) |
|-----------|---------------------|
| 5/8" - 11 | 150 - 175           |
| 3/4" - 10 | 210 - 260           |

**IMPORTANT**

Do not over-torque fasteners. Over-torquing can strip threads, collapse spacers or lead to other problems that cause loose fasteners. Use an accurate torque wrench when tightening fasteners.

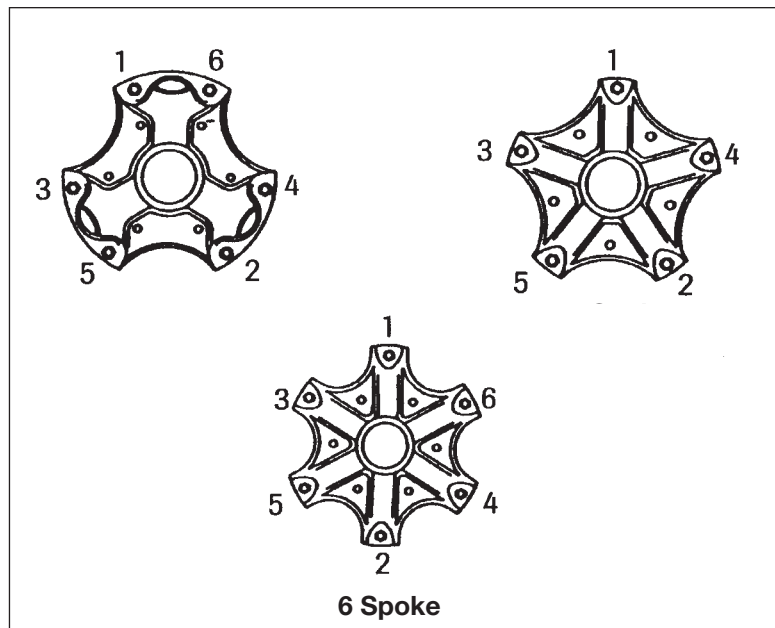

**Fig. 65 RIM/WHEEL TORQUE SEQUENCE**

## 5.2.7 TIRES

Tires are one of the most important components on a trailer and must be maintained in top condition to obtain their desired load carrying capacity and durability. Tire wear rate can be used as an indicator of the condition of the axle alignment or suspension system. Poorly maintained tires will wear rapidly or deteriorate and fail quickly and suddenly. A poorly maintained tire can and will affect adjacent components leading to their potential failure as well.

Proper tire maintenance includes but is not limited to:

### 1. **Inflation Pressure:**

Operating at an incorrect inflation pressure is the most common maintenance problem with tires. Tires should be checked frequently to be sure they are at their specified pressure.

It is recommended that tire pressure be checked at the start of each working day and at least one other time during the day. Always use an accurate hand gauge when checking the pressure and check each tire. Carry it with your unit so it is always available when needed. The most accurate pressure is obtained when the tire is cold. Every tire has its specified operating pressure molded into the sidewall. Adjust the pressure as required to obtain the specified inflation pressure when the tire is cold.

Tire pressure will normally increase 10 to 15 psi during operation as the tire heats up. If the pressure exceeds this normal increase, it indicates the tire may be overloaded, underinflated, driven too fast, improperly sized or a combination of these factors. Identify the cause of the problem and correct it before resuming work.

### a. **Underinflation:**

Operating at lower than the specified pressure is a tire's worst enemy. Use an accurate tire pressure gauge to check the pressure at the start of each working day, every few hours during the day and/or whenever the handling characteristics change suddenly. Underinflation will increase tread wear and cause a deterioration of the tire body leading to a separation of the tread from the body. An underinflated tire is soft and deflects more than it should causing fatigue cracks or breaks in the body cord construction leading to sudden air loss.

Operation with a low or flat tire on a dual will generate a lot of heat in the underinflated tire from internal friction that it can and will disintegrate or catch on fire. It also causes overloading of the adjacent tire on the axle or axles and could lead to their failure also.

### b. **Overinflation:**

Inflating a tire over its specified pressure can lead to serious problems also. Overinflation creates a more rigid tire that does not absorb road shocks as well as it should. Shock loading from impacting bumps or pot holes can break the fabric of the tire and/or transmit the higher loads into the rim, wheel and adjacent components causing them to fail as well. Overinflated tires cut, snag or puncture more easily than properly inflated tires. Also overinflating tire will not increase its load carrying capacity.

## 2. Tire Matching and Spacing on Duals

Tires on a dual assembly must be matched for size (diameter or rolling radius) and type of construction to obtain the desired and expected performance and life.

### a. Matching of Size:

Tire sizes can vary between manufacturers and as they wear. Special care must be taken to be sure the tire size (rolling radius, diameter or circumference) is within the following dimensions:

Rolling radius: 1/8 inch (3 mm)

Diameter: 1/4 inch (6 mm)

Circumference: 3/4 inch (19 mm)

Measure the tire when it is mounted, inflated to its specified pressure and not loaded. The easiest method is to use a steel tape to measure the circumference of the tire.

Unequal sized tires will require the larger tire to carry more of the load and potentially overload it. Overloading accelerates the wear and can lead to tire failure. When the one tire fails, the remaining tire or tires will then also be overloaded. The smaller tire will not contact the road surface properly and will wear in an irregular manner giving poor durability.

### b. Tire Construction:

Customers can use radial or bias ply tires on their trailer. However, it is recommended that different types of tires not be mixed on an axle. Each type of tire has different deflection, cornering and spring characteristics. These differing characteristics cause the tires to always fight each other during operation and will give erratic handling and poor wear characteristics when mounted on the same axle. Different types can be mounted on different axles but not on the same axle.

### c. Tire Spacing:

A wide variety of rims can be used on the trailer and each will provide a different offset. Select the rims to provide sufficient space and clearance between the sidewalls of the tires. Normally there should be at least 2 inches (50 mm) and 3 inches (75 mm) between the sidewall of a bias ply and radial dual tire assembly respectively. This spacing will provide sufficient clearance for each type of tire to deflect as they rotate and when they impact a pothole or bump in the road. If they touch during operation, they will wear or abrade at the contact point. In addition, tires that are too close do not shed dirt, trash or stones that can get between them during operation as well as properly spaced tires.

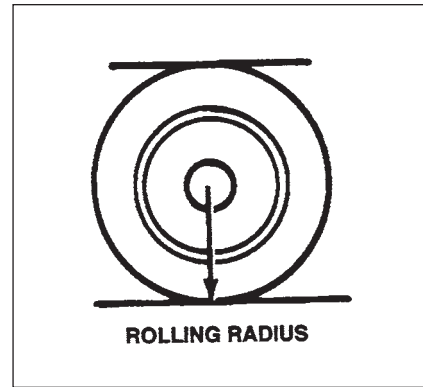
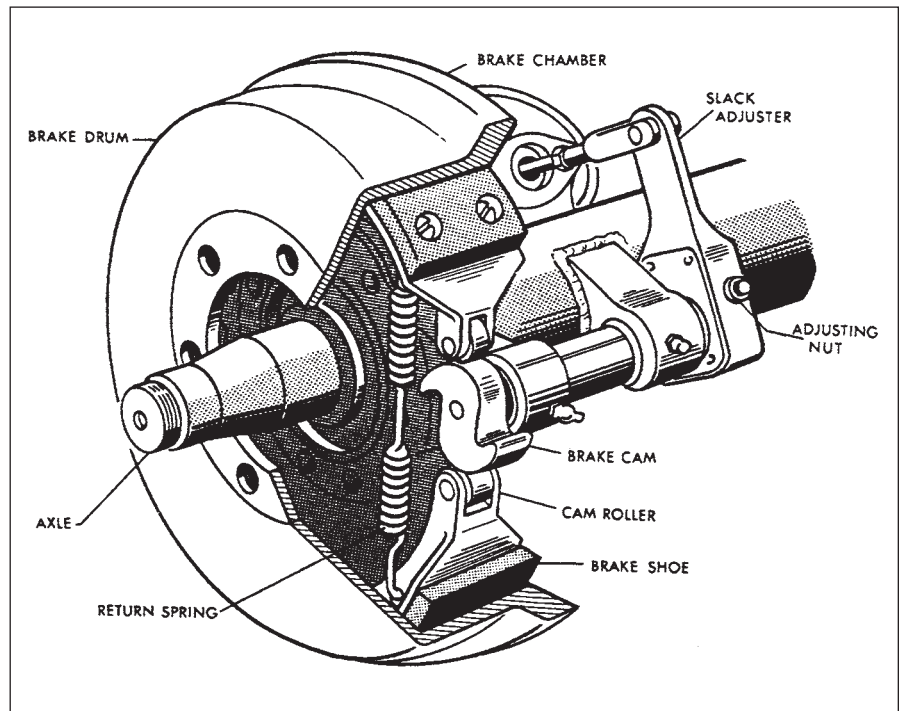

Fig. 66 TIRE DIMENSIONS

## 5.2.8 BRAKES

All components in the brake system must be maintained in good condition for the system to perform at top efficiency. It is recommended that brakes and associated components be checked, serviced and maintained per the Preventative Maintenance Schedule (PMP) for the trailer. In this section, the basic brake disassembly and assembly procedure will be covered. Refer to the axle manufacturers service manual for a more detailed repair and rebuilding procedure.

Check brakes frequently to keep them in top condition. Poorly maintained brakes will not stop the trailer as effectively as well-maintained brakes and in the extreme could fail completely leaving no brakes or no ability to stop the unit.

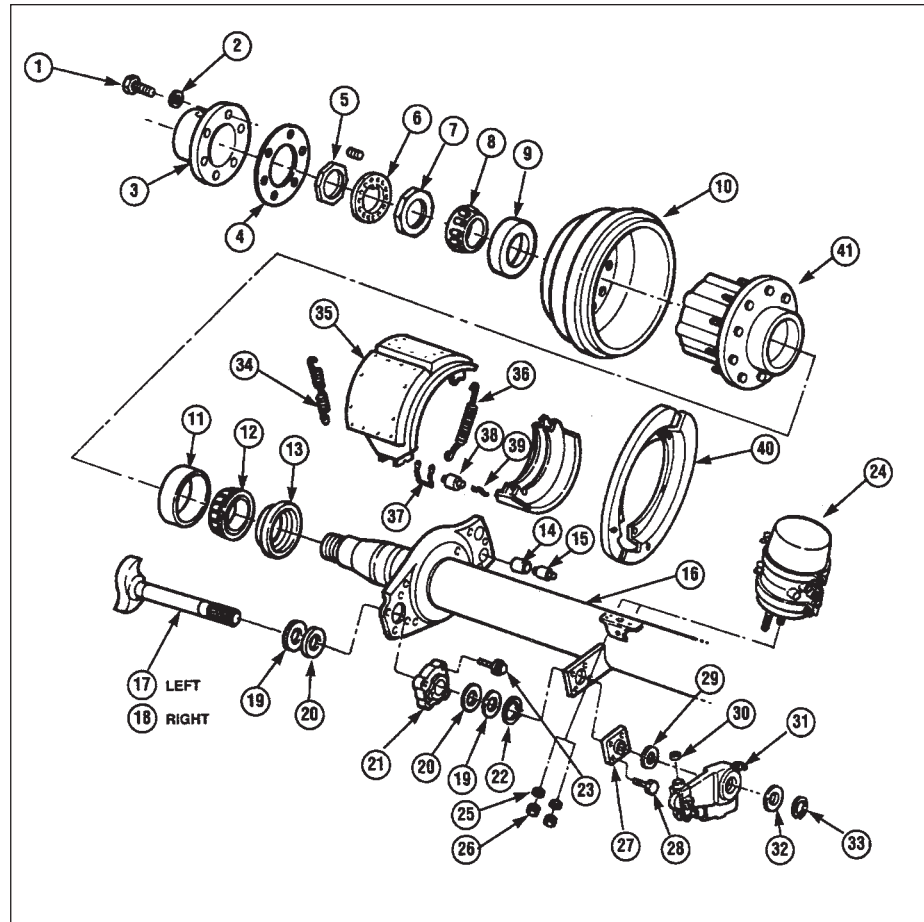

**Fig. 67 BRAKE SYSTEM**

It is recommended that the driver checks the brakes at least once during each working day when checking tire pressure and performing a quick visual of the unit. Place your hand on each brake drum to check the temperature of the drum. All drums should be approximately the same temperature if the system is functioning properly. If any drum is significantly warmer or colder than the rest, it indicates a problem. Determine the cause of the problem and correct it before resuming work. By discovering and correcting it while it is a minor issue; major repair, expense and down time can be prevented.

At 25,000 miles (40,000 km) or every 3 months when the axle is raised off the ground for the complete wheel end inspection, check the brakes at the same time. When the wheels are turned by hand, the wheel end should decrease speed slowly. If it does not, the brakes could be dragging or there could be a problem with the bearings. Dragging brakes will also be detected by hot drums during the daily drum temperature checks. Adjust the brakes to correct the problem.

Remove the brake dust covers (if so equipped) to access the shoes. Check the thickness of the linings. Reline or replace shoes when the lining thickness is less than 1/8 inch (3 mm). Uneven wear among the brake shoes on a trailer indicate that the braking system has not been set or maintained properly causing uneven application and wear. If uneven lining wear appears, reset the system to provide even application of all the shoes. Do not operate when the linings are less than 1/8 inch (3 mm) to prevent the lining anchor rivet or bolts from contacting the drum. Head contact with the drum will cut grooves in the surface and require extra machining to remove them when rebuilding the brakes.



**Fig. 68 EXPLODED VIEW**

Several types of friction material are available for use on the brake shoes. Each has its own friction coefficient and braking characteristics. Select the one that best fits your application but do not mix materials on the same trailer. Differing materials require different application forces to obtain the same braking force and a braking system can only apply one force when it is properly set.

Recent changes in environmental laws have banned the use of asbestos including brake linings. Always use the appropriate safety gear when removing brake shoes containing asbestos from your trailer. Replace the shoes that are equipped with approved material.



**Fig. 69 AXLE**

**A. Removing Brakes:**

1. Position the trailer on a level hard surface.
2. Exhaust all the air from the air system.
3. Jack the axle up and place on safety stands.
4. Remove the wheel assembly from the axle.
5. Release the slack adjuster (Refer to Section 5.2.6).
6. Disable or cage spring brakes if so equipped.
7. Drain oil from hub and remove spindle end components.
8. Remove the hub and drum assembly. Support with a hoist as the assembly slides off the spindle. Use a puller if required.
9. Remove roller retaining clip from the bottom and top brake shoe cam rollers.
10. Disconnect and remove bottom shoe return spring.
11. Rotate bottom shoe to remove retaining springs.
12. Lift top shoe to remove.
13. Disconnect push rod from slack adjuster.
14. Back off and remove slack adjuster.
15. Remove cam shaft.

**B. Installing Brakes:**

1. Inspect all the components. Replace any that are cracked, bent or worn.
2. Lubricate the camshaft spline, slack adjuster gear and slack adjuster pins with anti-seize compound.
3. Install cam shaft and slack adjuster. Secure with snap rings.
4. Adjust slack adjuster to its required angle and attach to the push rod. Release slack adjuster pawl if so equipped.
5. Use a good quality brake grease to lubricate the anchor pins and rollers where they contact the brake shoes.
6. Place the upper shoe in position.
7. Place the lower shoe in position and attach 2 new retaining springs.
8. Rotate lower shoe forward and attach new brake shoe return spring.
9. Install both cam rollers and secure with retainers.
10. Install and secure the remaining wheel and components.
11. Repeat with other wheel ends as required.
12. Tighten all fasteners to their specified torque.

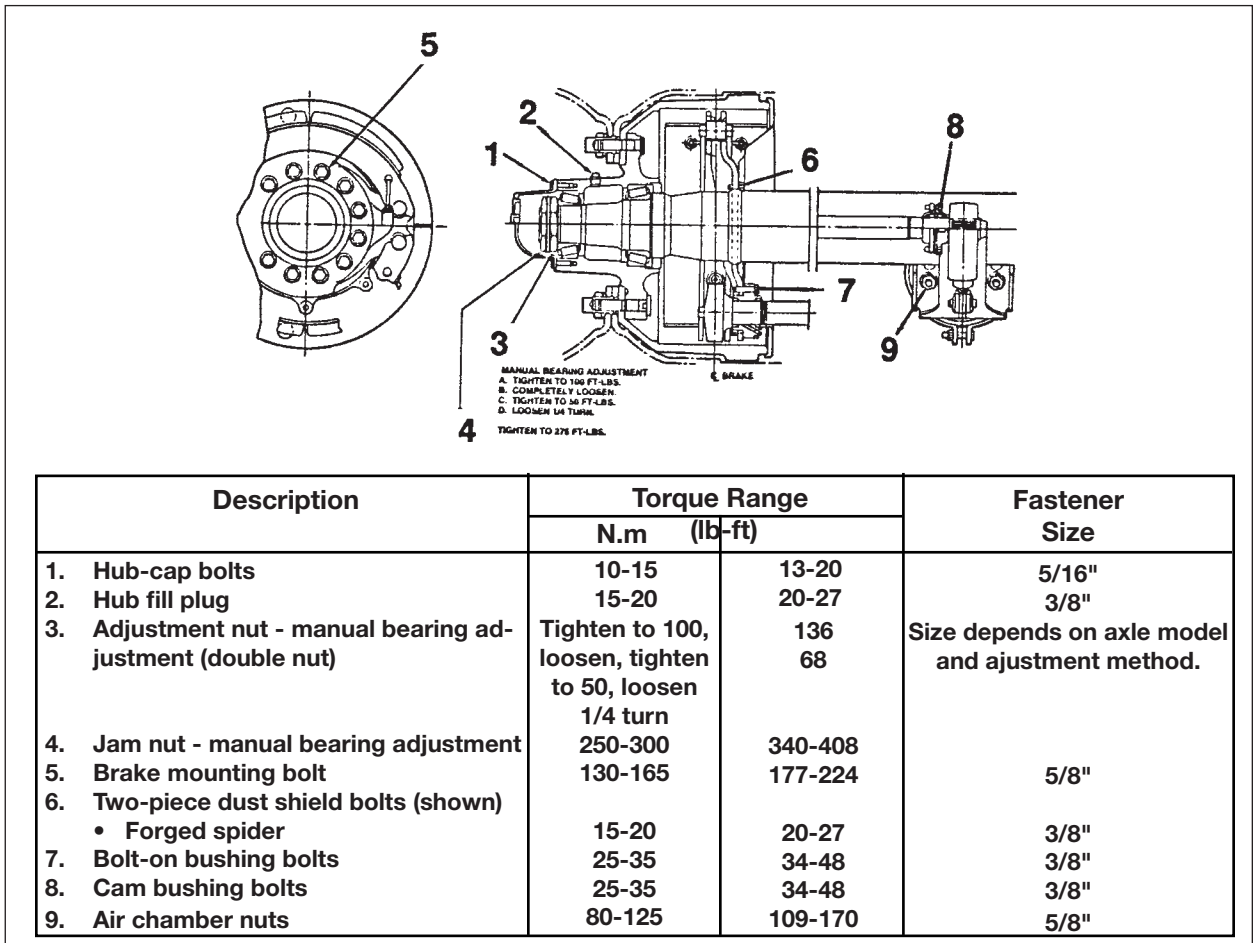

**Fig. 70 BRAKE/WHEEL END COMPONENTS**



## 5.2.9 SLACK ADJUSTERS

### 5.2.9.1 HALDEX AUTOMATIC SLACK ADJUSTER

The Haldex S-ABA automatic brake adjuster is a clearance sensing brake adjuster that maintains a nominal distance or clearance between lining and drum.

#### **When the Adjuster is Installed:**

With the brake in the released position, the control arm is fixed to the anchor bracket. The adjustment hex is rotated until the shoes contact the brake drum and then backed off 1/2 turn. When the brake is applied on the first application, the endless rack rotates to the correct position and sets itself.

#### **When the Brake Applies:**

When the brake is applied, the adjustment regulator rotates through the normal clearance angle and the shoes contact the drum. The torque increases and the wormshaft is moved axially, causing the coil spring to be compressed and the clutch wheel to disengage. The adjustment components are free to rotate as the brake continues to apply.

#### **When the Brake Releases:**

When the brake is released, the torque decreases returning the wormshaft to the clutch wheel and re-engaging the teeth. The adjustment regulator rotates through the normal clearance angle and the brake is released. If lining wear has taken place the adjustment regulator advances the clutch wheel reducing the excess clearance during the release stroke.

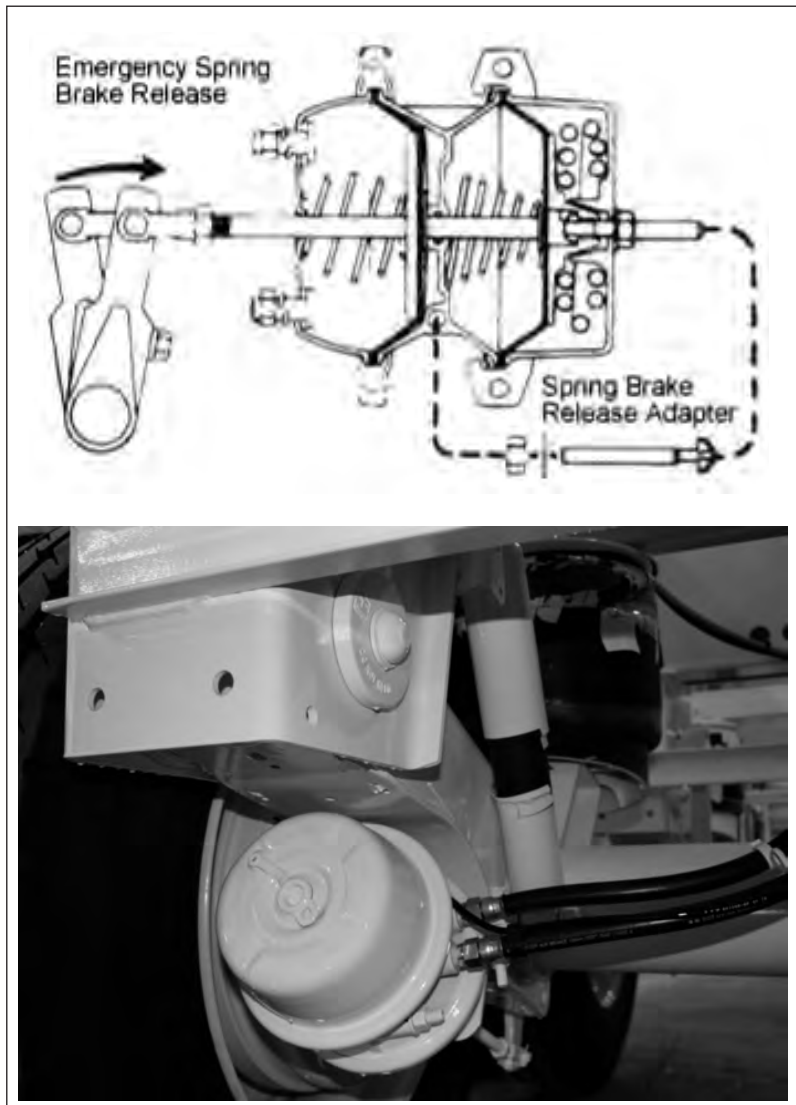

Fig. 71 HALDEX SLACK ADJUSTER (TYPICAL)

## 5.2.9 SLACK ADJUSTERS (cont'd)

### 5.2.9.2 AUTOMATIC SLACK ADJUSTER MAINTENANCE

In an S-cam type foundation brake, the final link between the pneumatic system and the foundation brake is the slack adjuster. The arm of the slack adjuster is fastened to the push rod of the chamber with a clevis and the spline end is installed on the brake camshaft.

Primarily, the slack adjuster is a lever that converts the linear force of the air chamber push rod into a torque which turns the brake camshaft and applies the brakes.

### IMPORTANT

Automatic slack adjusters are for brake adjustment and will not compensate for faulty foundation brakes.

#### Routine Visual/Operational Checks

- Haldex strongly recommends that routine visual/operational checks, including brackets and control arms, be performed at each Preventative Maintenance Service Interval.
- Adjusters or anchor brackets that have visual damage, or which fail the operational checks, **MUST** be replaced immediately.
- Automatic adjusters should not be operated as manual adjusters except as may be necessary to get the vehicle off the road for service.

**Service and Lubrication Intervals for Standard Haldex AA1 and S-ABA Brake Adjusters**

| Adjuster Type                          | Manufacture Date | Lubrication Interval           | Type of Lubricant       | Visual Check Interval                          |
|--|------------------|--------------------------------|-------------------------|--|
| Standard Adjuster 409-10...            | Prior to 6/1/96  | 50,000 miles or every 3 months | Standard Chassis Grease | Each Preventative Maintenance Service Interval |
| Reduced Maintenance Adjuster 409-10... | After 6/1/96     | Once a year                    | Standard Chassis Grease | Each Preventative Maintenance Service Interval |
| No-Lube™ Adjuster 429-10...            | After 6/1/96     | None                           | Sealed Unit             | Each Preventative Maintenance Service Interval |
| S-ABA Adjuster 409-20...               | n/a              | Once a year                    | Standard Chassis Grease | Each Preventative Maintenance Service Interval |



#### Notes:

No-Lube™ automatic brake adjusters are manufactured without a grease fitting and are identified by a 429 prefix.

**Moly-disulfide grease should not be used because it may affect the function of the internal friction clutches and reduce the reliability of the automatic adjustment.**

In no case should the lubrication interval exceed the published intervals shown above.

## AUTOMATIC SLACK ADJUSTERS

While automatic slack adjuster designs vary in the manner in which they are installed and operate, all are designed to automatically maintain a predetermined shoe-to-drum clearance or brake chamber stroke. Some automatic slack adjusters adjust upon the brake application stroke, others adjust upon release. Automatic slack adjusters can greatly reduce manual adjustments. **Automatic slack adjusters do not reduce the need for periodic maintenance.**

### Automatic Brake Adjuster Checking Procedures

If the brake adjuster is not maintaining the proper applied stroke, **before removing the brake adjuster**, check the condition of the foundation brake. **If after inspecting the foundation brake** no apparent problems are found, inspect the automatic brake adjuster to determine if it is operating properly. The inspection can be performed on or off the vehicle using the following procedures.



#### Note:

- Block wheels to prevent vehicle from rolling.
- Ensure system reservoir pressure is at 90-100 PSI.
- Check that push rod is fully retracted; apply air to release spring brake.
- If air is not available, spring brake must be manually caged back.
- Do not use air tools on brake adjuster!

## Automatic Brake Adjuster Operational Check

**Functional operation of the brake adjuster can be performed on the vehicle by using the following procedure:**



- Block wheels to prevent vehicle from rolling.
- Ensure reservoir pressure is at 90-100 psi.
- Check that the push rod is fully retracted; apply air to release spring brake. If air is not available, spring brake must be manually caged back.

Manually de-adjust brakes (turn adjustment hex counterclockwise one full turn) to create an excessive lining to drum clearance condition. (A ratcheting sound should occur.)

Make a full service brake application. On release, allow sufficient time for air chamber to fully retract.

During the brake release, observe rotation of the adjustment hex (attaching a wrench on the hex or scribing the hex will make this rotation easier to see).

This rotation indicates that an excessive clearance condition has been determined by the brake adjuster, and it is making an adjustment to compensate. On each subsequent brake **release**, the amount of adjustment and push rod travel will be reduced until the desired lining to drum clearance is achieved.

If rotation of the adjustment hex is not observed, refer to Foundation Brake Operational Check and Troubleshooting Procedures at [www.haldex.com](http://www.haldex.com). If foundation brake assembly checks out okay and hex still does not turn, check control arm and mounting bracket for possible worn, bent or broken components. If the control arm and mounting bracket check out okay, replace the adjuster and hardware per Installation Instructions at [www.haldex.com](http://www.haldex.com).

### On Vehicle Inspection

#### Component

Excessive chamber push rod travel

#### Cause

Improper anchor bracket connection to control arm

Low clutch torque

Unknown

#### Action

If anchor bracket to control arm connection is worn, loose, bent or broken, it must be re-secured or replaced.

Rotate the 7/16" adjustment hex one full turn counterclockwise. Replace brake adjuster if the torque is less than 13 ft. lbs. or no ratcheting sound occurs.

Perform automatic brake adjuster operational check (see below).

## 5.2.9 SLACK ADJUSTERS (cont'd)

### 5.2.9.2 AUTOMATIC SLACK ADJUSTER MAINTENANCE (cont'd)

#### BRAKE ADJUSTMENT PROCEDURE

##### NOTE

All adjustments should be made with cold brake drums and the brakes fully released.



## WARNING

To avoid possible injury, proper precautions must be taken to prevent automatic actuation of the brake chambers while adjusting slack adjusters. Always block the wheels or mechanically secure the vehicle. Spring brakes must be mechanically caged or released with air. All brakes should be released.

#### Foundation Brake Operational Check and Troubleshooting



##### Note:

- Block wheels to prevent vehicle from rolling.
- Ensure system reservoir pressure is at 90-100psi.
- Check that push rod is fully retracted; apply air to release spring brake.

#### North American Commercial Vehicle Safety Alliance (CVSA) Uniform Vehicle Inspection Criteria

The applied stroke of the brake should be checked per CVSA guidelines at 90-100 PSI reservoir pressure. Applied stroke should be at or less than the specified re-adjustment limits as follows:

| Standard Clamp Type Brake Chamber |                  |      |                  |
|-----------------------------------|------------------|------|------------------|
| Type                              | Adjustment Limit | Type | Adjustment Limit |
| 9                                 | 1-3/8"           | 24   | 1-3/4"           |
| 12                                | 1-3/8"           | 30   | 2"               |
| 16                                | 1-3/4"           | 36   | 2-1/4"           |
| 20                                | 1-3/4"           |      |                  |

| Long Stroke Type Brake Chamber |                  |      |                  |
|--------------------------------|------------------|------|------------------|
| Type                           | Adjustment Limit | Type | Adjustment Limit |
| 16L                            | 2"               | 24LS | 2-1/2"           |
| 20L                            | 2"               | 30LS | 2-1/2"           |
| 24L                            | 2"               |      |                  |

NOTE: Long stroke chambers are identified with square air ports or port bosses and special trapezoid ID tags.



## Free Stroke

### Measuring the Free Stroke

Free stroke is the amount of movement of the adjuster arm required to move the brake shoes against the drum. With brakes released, measure from the face of the chamber to the center of the clevis pin "A" (fig. 13). Use a lever to move the brake adjuster until the brake shoes contact the drum "B" (fig. 13). The difference between the fully retracted and drum contact measurement "B"–"A" (fig. 13), is the free stroke. The free stroke range should fall between 3/8"–3/4".

### Free Stroke Within Range

If the free stroke is good, but the applied stroke is too long, there is probably a problem with the foundation brake. Check the following and reference CVSA out-of-service criteria:

| <b>Component</b>    | <b>Cause</b>                 | <b>Action</b>                                  |
|---------------------|------------------------------|--|
| Brake drums         | Cracked or out of round      | Replace or check drum run out                  |
| Brake shoes         | Shoe span out of spec        | Refer to OEM specs and replace if necessary    |
| Brake shoes         | Uneven lining wear           | Check spider concentricity                     |
| Brake shoes         | Shoe pad missing             | Remove & replace shoes                         |
| Brake shoes         | Cracked shoes                | Remove & replace shoes                         |
| Cam bushings        | Excessive movement           | Remove & replace cam bushings per OEM specs    |
| Camshaft            | Flat spots on cam head       | Replace camshaft                               |
| Camshaft            | Cracked/broken splines       | Replace camshaft                               |
| Camshaft            | Worn bearing journals        | Replace camshaft                               |
| Chamber bracket     | Broken/bent                  | Replace bracket                                |
| Clevis yoke and pin | Worn                         | Remove & replace                               |
| Return springs      | Broken/stretched or missing  | Remove & replace springs                       |
| Rollers             | Flat spots, grooved pin/worn | Remove & replace roller and pin                |
| Rollers             | Wrong size                   | Remove & replace with correct parts            |
| Spider anchor pins  | Grooved or scored/worn       | Replace spider or pins, as appropriate for OEM |

### Free Stroke Above the Range

If the free stroke is above the range and the applied stroke is too long, there is a problem with the foundation brake or the adjuster. Check the following:

| Component                  | Cause                      | Action   |
|----------------------------|----------------------------|--|
| Camshaft                   | Binding                    | Remove, replace, lubricate camshaft  |
| Camshaft bushings          | Excessive movement         | Remove and replace cam bushings per OEM specs  |
| Camshaft bushings          | Binding shaft              | Lubricate camshaft bushings or replace   |
| Air chamber return springs | Broken, weak, missing      | Replace chamber  |
| Air chamber push rod       | Binding on chamber housing | Check adjuster for proper shimming and air chamber position for proper adjuster arm length   |
| Air system                 | Not exhausting completely  | Check for cause of air problem and repair  |
| Shoe return springs        | Broken, weak, missing      | Replace springs  |
| Automatic brake adjuster   | Unknown                    | Check automatic brake adjuster for proper installation. Refer to Installation Instructions at <a href="http://www.haldex.com">www.haldex.com</a> . |
| Automatic brake adjuster   | Unknown                    | Refer to Automatic Brake Adjuster Checking Procedures and Operational Check at <a href="http://www.haldex.com">www.haldex.com</a> .                |

### Free Stroke Below the Range

If the free stroke is less than 3/8", a dragging brake can occur. Check the following:

| Component                | Cause             | Action   |
|--------------------------|-------------------|--|
| Wheel bearing            | Out of adjustment | Readjust per OEM specs   |
| Automatic brake adjuster | Unknown           | Check automatic brake adjuster for proper control arm position. Refer to Installation Instructions at <a href="http://www.haldex.com">www.haldex.com</a> . |
| Automatic brake adjuster | Unknown           | Refer to Automatic Brake Adjuster Checking Procedures and Operational Check at <a href="http://www.haldex.com">www.haldex.com</a> .                        |

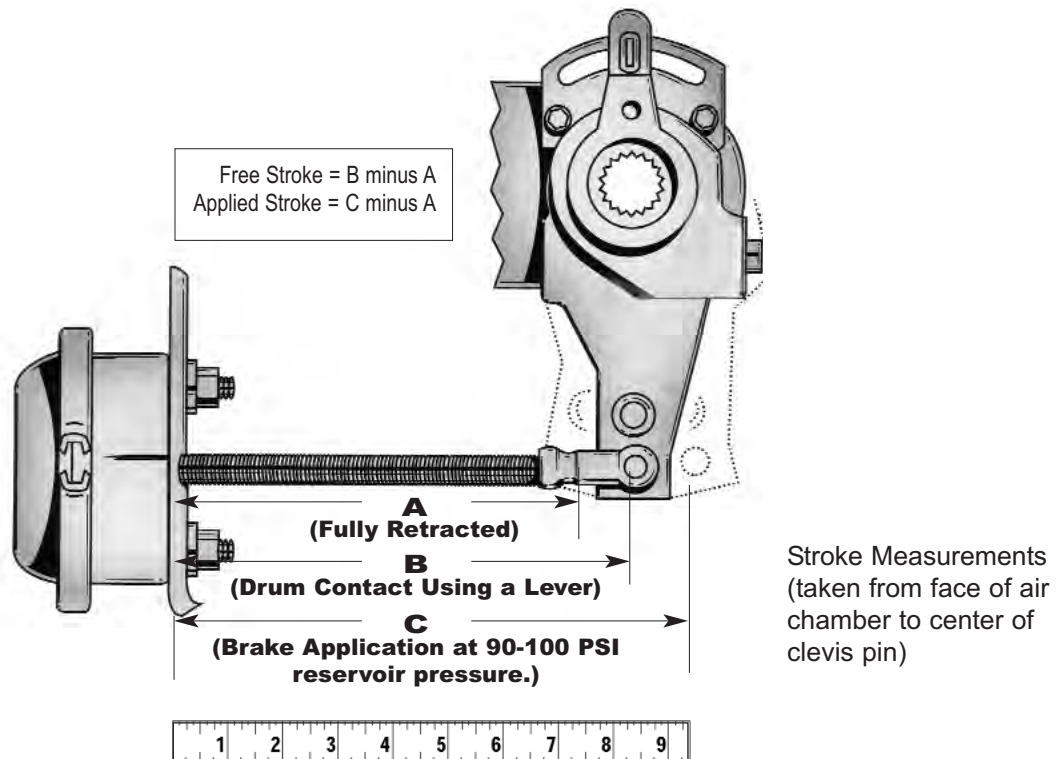



## FAILURE ANALYSIS

### Automatic Slack Adjuster Failure Analysis

If the power stroke is at or more than the maximum stroke, measure free stroke to determine if the slack adjuster is operational.

### FREE STROKE MEASUREMENT

Free stroke is the amount of slack arm movement required to move the brake shoes against the drum. To measure free stroke, perform the following:

1. With brakes released, measure from the brake chamber face to the center of the clevis pin.
2. With a lever, pry the slack adjuster arm until the brake shoes contact the drum and measure the slack adjuster movement (see Fig. 72).
3. The difference between the brake released and applied measurements is the free stroke. The free stroke should be  $3/8"$  -  $5/8"$ . If the free stroke is in the correct range, the out of spec stroke is due to a foundation brake problem. Check for missing or worn components, cracked brake drums, or improper lining-to-drum contact. If the free stroke is greater than recommended, an automatic slack adjuster function test should be performed.

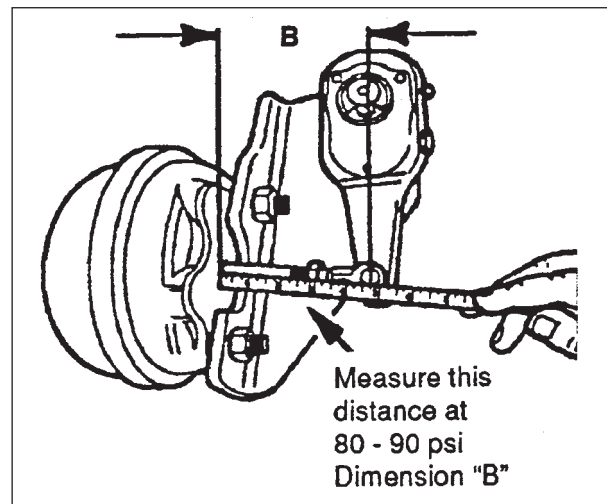
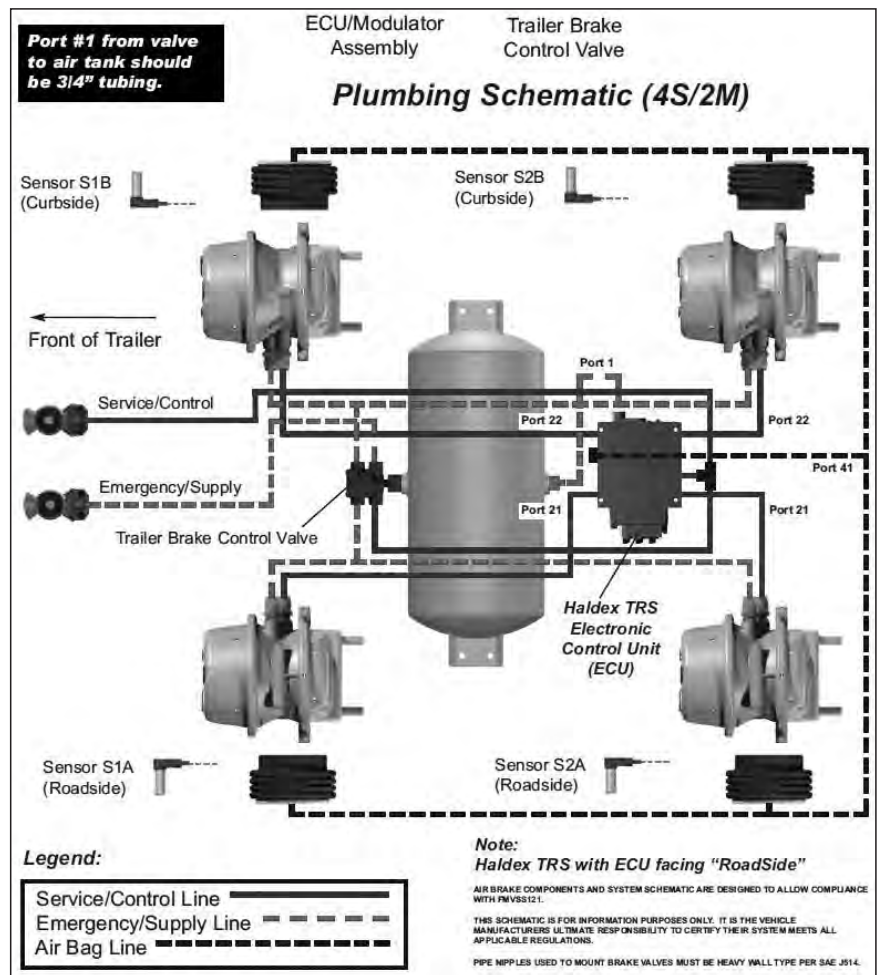

Fig. 72 FREE STROKE

## 5.2.10 TRAILER ABS

Each trailer is designed with an ABS (Automatic Braking System) to increase the effectiveness of the brakes during stopping. The system consists of valves, sensors, exciter rings and an Electronic Control Unit.



Review the brochures included in the documentation package to become familiar with the ABS system and installation. The system is installed on each axle and controlled by the air system.

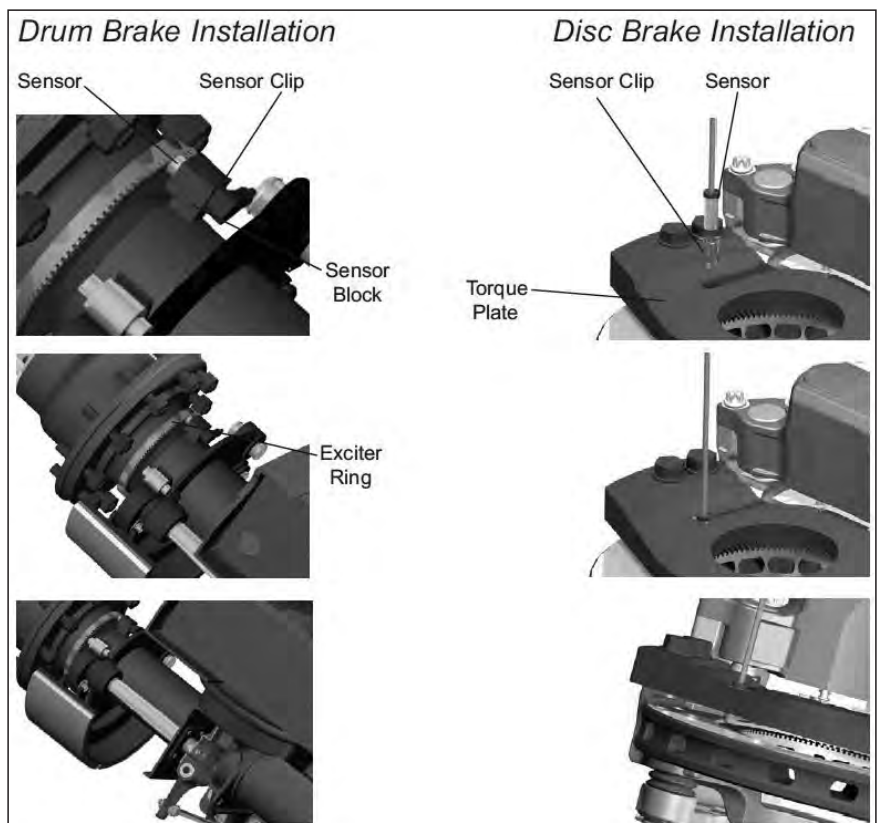

## 5.2.11 AIR CHAMBER/SPRING BRAKE

Air chambers mounted on the axle use the air supply/pressure from the tractor to apply the service brakes for stopping the vehicle. In addition this air chamber may be equipped with a spring brake that applies the brake when the service side of the brake loses air. The spring brake side of the system is used as a parking and/or emergency brake if the service side fails.

Spring brakes should not be serviced by anyone in the field unless they have been trained in the proper procedure. Do not open the air chamber unless the spring is caged or locked out. Do not work on the brakes unless the springs are caged or locked out. Do not move the trailer if the springs are caged.

When caging or locking out the spring brakes, follow this procedure:

1. Place chocks in front of and behind the trailer wheels.
2. Insert the release bolt, stored on the side of the chamber, into the hole in the head and through the piston.
3. Turn the release bolt clockwise until it stops and locks.
4. Pull release bolt out as far as possible and run the nut down while holding the bolt in place.
5. Use a wrench to turn the release bolt nut clockwise until the bolt extends about 3 inches.
6. Be sure the release bolt is locked in position.
7. The spring is now caged and the trailer can be moved.
8. Always release the spring before placing the trailer back in service.

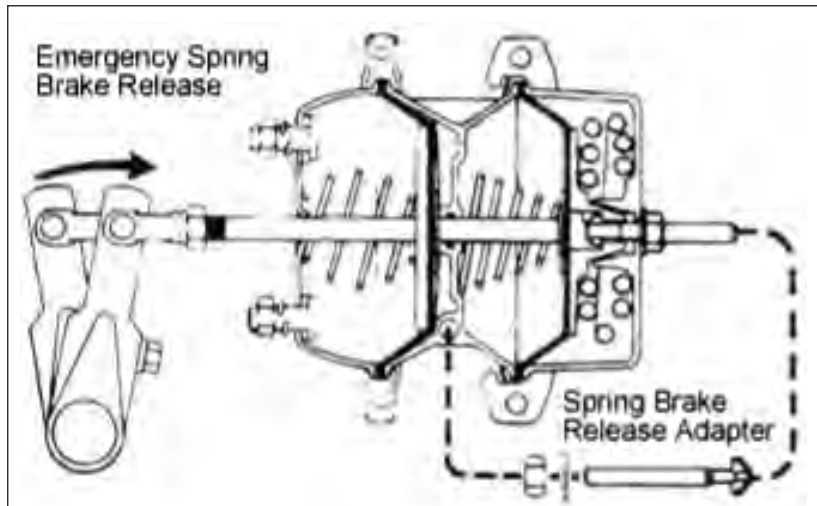

Schematic



Axle

Fig. 73 SPRING BRAKE

## 5.2.12 SUSPENSION SYSTEM

The suspension system is the group of components that connect the axle to the main trailer frame and absorb the shock loads from the road. Midland trailers can be equipped with either a mechanical or air ride suspension system. Either system works well and will provide many years of trouble-free service.

### 5.2.12.1 AIR RIDE SUSPENSION

An air ride suspension consists of air springs that are inflated and pressurized by the trailer air system and controlled by a height control valve. It is a simple system that requires minimal servicing and maintenance to perform well.

Visually inspect the trailer at the start of the day or trip to check the condition of the suspension. Ensure that the ride height is set as per proper specifications. Also, check for loose fasteners or damaged components. Correct any problems before placing the trailer into service. Problems caught early and corrected minimize cost and downtime.

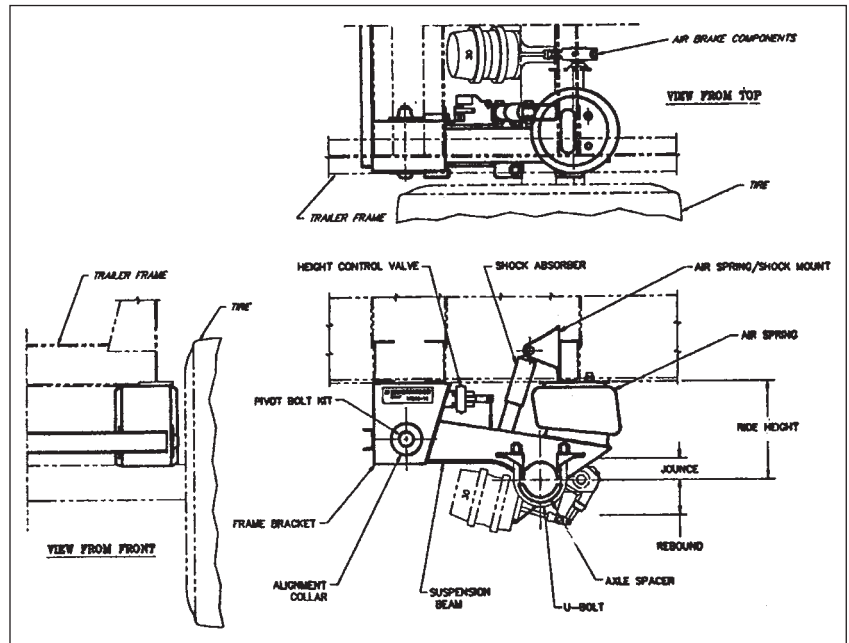

Fig. 74 SUSPENSION

Every 5,000 miles (8,000 km) or monthly, check the clearance around all the suspension system components. Correct any interference problem. Retorque all the fasteners to their specified torque.

| RIDEWELL SUSPENSION TORQUE CHART |              |         |       |  |
|----------------------------------|--------------|---------|-------|--|
| ITEM                             | SIZE         | TORQUE  |       |  |
|                                  |              | (FT-LB) | (N-m) |  |
| Pivot Bolt/Nut                   | 1 1/4" - 7NC | 1,000   | 1,350 |  |
| Shock Bolt/Nut                   | 3/4" - 10NC  | 200     | 270   |  |
| Air Spring Bolt/Nut              | 1/2" - 13NC  | 25      | 35    |  |
| Air Spring Bolt/Nut              | 3/4" - 16NF  | 50      | 70    |  |

After suspension has been in operation for approximately 5,000 miles (10,000 km), all fasteners must be re-tightened to specified torque. Repeat every 50,000 miles (80,000 km).

**DO NOT OVER-TORQUE!**

| RAR-260 Trailer Suspension - Torque Specifications   |            |               |  |  |
|--|------------|---------------|--|--|
| Fastener Type  | Size       | foot-pound    | Torque Values<br>Newton-meter  |  |
| Pivot Bolt - (Shear-Type)<br>Pivot Nut - (Locknut)<br><i>Requires E-20 Torx<sup>®</sup> socket (RW #6100054)</i> | 7/8" - 9NC |               | Do not lubricate bolt/nut threads. Use a 1" drive impact wrench to tighten the pivot bolt until the Torx <sup>®</sup> head is sheared off. |  |
| Locknut - (Shock Absorber)   | 3/4"-10NC  | 200-230 ft-lb | 271-312 N-m  |  |
| Nut - (Air Spring)   | 3/4"-16NF  | 45-50 ft-lb   | 61-68 N-m  |  |
| Locknut - (Air Spring)   | 1/2"-13NC  | 20-25 ft-lb   | 27-34 N-m  |  |
| Locknut - (Air Spring - 25K O/S)   | 1/2"-13NC  | 45-50 ft-lb   | 61-68 N-m  |  |
| Bolt - (Air Spring)  | 1/2"-13NC  | 20-25 ft-lb   | 27-34 N-m  |  |

Refer to the engineering drawing for component torque value. Torque values reflect a lubricated thread condition (Nuts are pre-lubed). Do not overtorque.

**CAUTION:** Suspension is shipped with minimal torque applied to fasteners. It is the installer's responsibility to apply the proper torque values. All fasteners, except for shear-type pivot bolt, must be re-torqued after the first 6,000 miles of operation. Failure to install and maintain suspension component fasteners at torque specifications could result in suspension failure and void the warranty.

### HENDRICKSON TAILER SUSPENSION BOLT TORQUE VALVES

| COMPONENT DESCRIPTION  | FT-LBS     | N-m          |
|--|------------|--------------|
| QUIK-ALIGN <sup>®</sup> Pivot Connection   | 505 to 595 | 685 to 807   |
| Welded Pivot Connection (1 1/8 inches)   | 750 to 825 | 1017 to 1119 |
| U-Bolts (HT Series)  | 475 to 525 | 644 to 712   |
| Shock Bolts  | 210 to 235 | 285 to 319   |
| Upper Air Spring Nuts (3/4 inch)   | 80 to 100  | 108 to 136   |
| Upper Air Spring Nuts (1/2 inch)   | 40 to 50   | 54 to 68     |
| Lower Air Spring Bolts (HT Series, AAEDT 30K, AAEDL 30K and HRRNT 40K / HRRNT 50K) | 40 to 50   | 54 to 68     |
| Lower Air Spring Nut (INTRAA <sup>®</sup> and VANTRAA <sup>®</sup> )               | 55 to 60   | 75 to 81     |
| Brake Chamber Mounting Nut (INTRAA <sup>®</sup> )                                  | 100 to 110 | 136 to 149   |
| S-Cam Support Bearing Mounting Nut (INTRAA <sup>®</sup> )                          | 35 to 45   | 47 to 61     |
| Hubcap Mounting Bolts  | 12 to 18   | 16 to 24     |
| Body Rail Clip   | 65 to 75   | 88 to 102    |
| Lift Mechanism Air Spring, Actuator (3/4 inch)                                     | 45 to 55   | 61 to 75     |
| Lift Mechanism Air Spring, Actuator (3/8 inch)                                     | 15 to 20   | 20 to 27     |

| COMPONENT DESCRIPTION                           | IN-LBS    | N-m        |
|---|-----------|------------|
| ABS Bracket Bolt and Nut (INTRAA <sup>®</sup> ) | 75 to 100 | 8 to 11    |
| Disc Brake Dust Shield Clamp                    | 50 to 70  | 5.6 to 7.9 |
| Drum Brake Dust Shield Clamp                    | 90 to 125 | 10 to 14   |
| Height Control Valve Mounting                   | 60 to 80  | 7 to 9     |

<sup>1</sup> Torque values in this table are for fasteners as supplied by Hendrickson Trailer Suspension Systems.

**IMPORTANT: DO NOT APPLY ADDITIONAL LUBRICANT TO FASTENER THREADS. DOING SO WILL REDUCE THE FRICTION BETWEEN FASTENER COMPONENTS, WHICH CAN LEAD TO OVERTIGHTENING, UNPREDICTABLE CLAMP LOADS AND UNRELIABLE FASTENER CONNECTIONS**



Every 25,000 miles (40,000 km) or 3 months, visually inspect all components and welds for cracks, distortions or other damage. Repair or replace all defective components before placing unit into service.

Typical repairs include but are not limited to:

**1. Air Spring Replacement:**

Air springs are designed to be virtually trouble-free throughout their life. Problems seldom occur unless they are cut, punctured, abraded, pinched or torn and then they must be replaced.

- a. Block the wheels to prevent trailer movement.
- b. Exhaust air from the suspension system.
- c. Raise and support the frame on safety stands.

**NOTE**

Do not raise frame too high unless shock absorbers are installed to prevent over-extending the air spring.

- d. Disconnect the air lines to the air spring(s).
- e. Loosen mounting bolts and remove air spring(s).
- f. Install new air spring(s).
- g. Tighten mounting bolts to their specified torque of 50 ft. lbs. (68 N.m).
- h. Install air lines and tighten to their specified torque.
- i. Repeat on other air springs.
- j. Remove stands from under frame.

**2. Shock Absorber Replacement:**

Shock absorbers remove energy from the suspension system as the trailer encounters holes and bumps on the road surface. They also act as a stop for the air springs to prevent the axle from moving too far away from the frame and tearing or damaging the air spring.

- a. Remove the upper and lower mounting bolts.
- b. Remove old shock and install new one.

**IMPORTANT**

Use only correct original equipment replacement parts. Substitute parts do not work with the suspension system.

- c. Secure shock by tightening mounting bolts to their specified torque of 250 ft. lbs. (338 N.m).

**3. Pivot Bushing:**

Pivot bushings are a very durable, long lasting component. Bushing failures are rare and should be attempted only when all other problem causes have been eliminated. For pivot bushing replacements please see your dealer or trailer repair shop.

4. **Air Control (Ride Height Control):**

An air ride suspension system uses the air from the tractor to pressurize the air springs. A single height control valve is used to monitor the height of the frame above the axle and add/exhaust air from the system as required to maintain this dimension. Normally this dimension is set for your trailer and seldom changes.

The height control valve is located on one of the axles and controls the adding/exhausting of air to the air springs. As the dimension between the frame and axle increases, the control lever moves down and air is exhausted from the system. As the dimension decreases, air is added to raise the frame. All valves incorporate a 5 to 15 second time delay to minimize jerking or cycling. Replace valve if not functioning properly.

Check ride height after first use and periodically thereafter to maintain proper ride height. Improper ride height can cause severe component damage and void your warranty. Maintaining correct ride height is the responsibility of the operator.

There are two different ride heights. (15" and 17") All trailers with the exception of B-Train lead are 17" ride height. The B-Train lead is 15". This measurement is taken from the centre of the axle to the underside of the frame.

**NOTE: measure the axle that has the ride height control mounted to it. The other axle(s) may have more or less distance between the frame and axle depending on height of fifth wheel. If ride height is incorrect contact your dealer.**

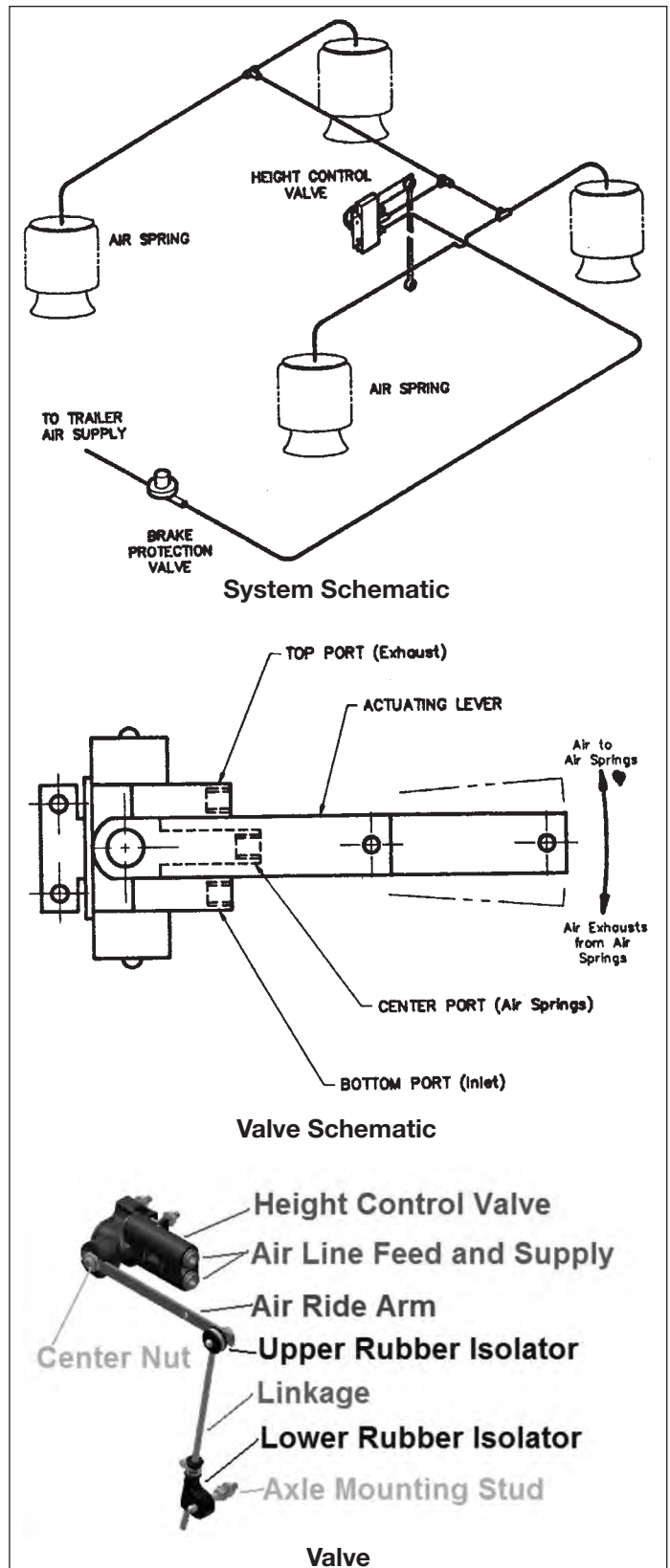

Fig. 75 RIDE HEIGHT CONTROL



5. **Dump Valve:**

All air ride systems are equipped with a dump valve that allows the operator to exhaust the air from the system as required.

- a. Always dump the air when parking the trailer and before unhooking.
- b. Dumping the air when unloading is not recommended.

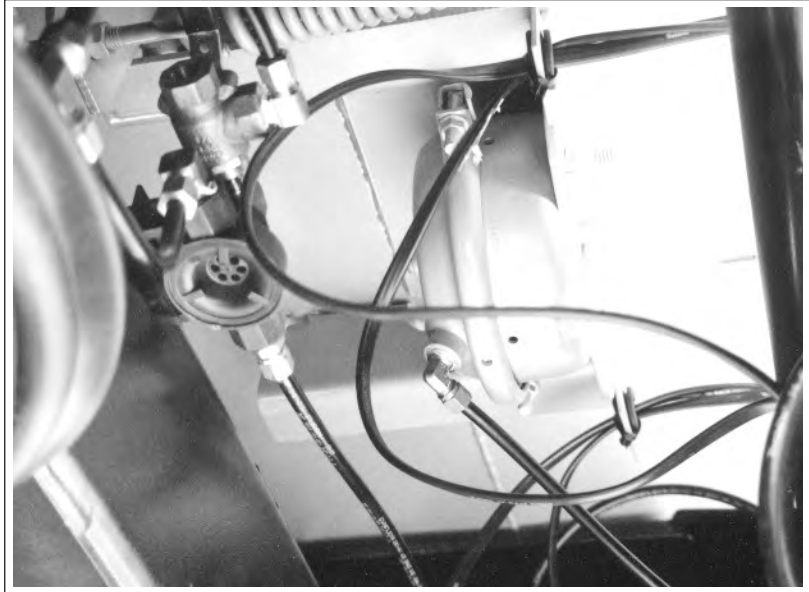

**Fig. 76 DUMP VALVE (Only on trailers with lift axle(s))**

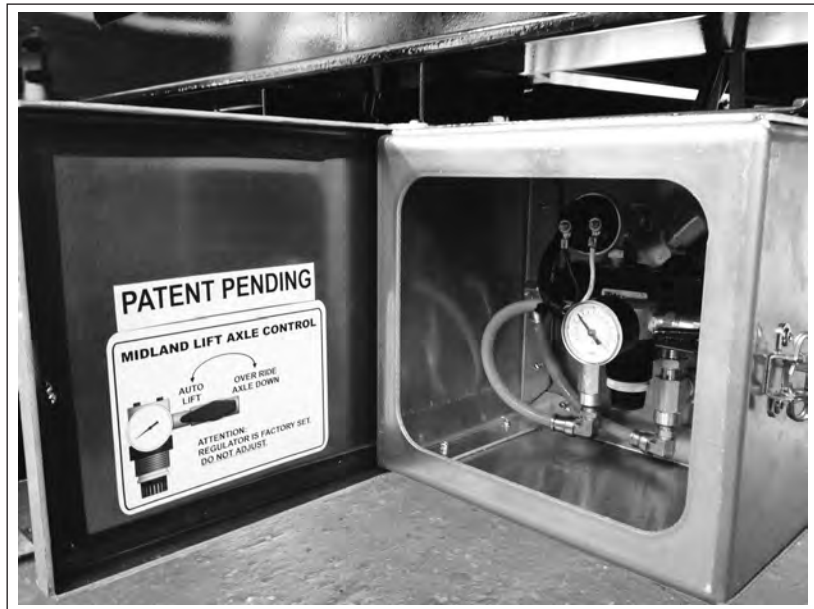

**MIDLAND LIFT AXLE CONTROL**

## 5.2.12.2 MECHANICAL SUSPENSION

Two types of mechanical suspensions are available on the trailer and must be specified and ordered from the factory. Both work well and provide the customer with a choice.

The two types of suspension for the tandem and triaxle models are the Hutch 9700 3 leaf and the Reyco 21B. Both are designed to require minimal service and maintenance on a trailer. However, these service intervals and maintenance procedures must be followed:

### Service Intervals:

1. Follow the break-in procedure specified in Section 4.3.
2. Visually inspect the suspension at the start of the day or trip for bent, broken or loose components. Always correct these conditions and perform a complete check-out of the suspension before placing the trailer back in service.
3. After each additional 25,000 miles (40,000 km), or every 3 months, retorque all the fasteners to their specified torque per the following table. Always use an accurate torque wrench when retorquing fasteners and attach to the nut.
4. 25,000 miles (40,000 km) or every 3 months, inspect the following:
  - a. Check position of clamp if moveable clamps used. Clamping legs must be centered over slot in end tube.

- b. Check fit and function of all bushings.
  - c. Check all hanger and hanger bracing welds for cracks.
  - d. Check all other welds for signs of cracks or distortion.
  - e. Check fit of springs in hangers and equalizers.
  - f. Check equalizers for excessive wear at spring ends.
  - g. Check suspension system alignment.
5. In addition to checking the alignment at the recommended intervals, axle alignment should be checked when any of the following conditions occur:
    - a. Discovery of loose fasteners or components.

### IMPORTANT

A loose fastener is defined as one whose torque has dropped below its specified level.

- b. Discovery of elongated holes in a suspension system component.
- c. Whenever bushings are replaced.
- d. Whenever excessive or abnormal tire wear is observed.

**Table 10**  
**Suspension Fastener Torque Requirements**

|  <b>WARNING</b>  |                        |
|---|------------------------|
| SAFETY ALERT! (1) FOLLOW ALL TORQUE REQUIREMENTS. (2) DO NOT USE ANY COMPONENT WITH VISIBLY WORN OR DAMAGED THREADS. FAILURE TO FOLLOW THESE SAFETY ALERTS CAN LEAD TO LOSS OF VEHICLE CONTROL, PROPERTY DAMAGE, SERIOUS PERSONAL INJURY OR DEATH.    |                        |
| <b>Hutchens Suspension Torque Requirements</b><br><b>9600-9700 Series (Decal Part Number 16086-01 Rev. J)</b>   |                        |
| After an initial break in period, approximately 1000 miles, and at least every 4 months periodically thereafter, ALL bolts and nuts should be checked to insure that recommended torque values are being maintained.                                  |                        |
| Oiled torque values listed are for new fasteners with lubricated threads. It is recommended that new installations be performed with oiled fasteners. For dry threads which have been in service, use the higher torque values which are noted below. |                        |
|   | <b>OILED      DRY</b>  |
| 1 1/8-7 (9600 / 9700 Rocker Bolt).....  | 590 lb-ft    790 lb-ft |
| 1-14 or 1-9 (9700 Radius Rod Bolt).....   | 540 lb-ft    720 lb-ft |
| 7/8-14 (Axle U-Bolts & 9600 Radius Rod Bolt).....   | 350 lb-ft    470 lb-ft |
| 3/4-16 (Axle U-Bolts).....  | 310 lb-ft    420 lb-ft |
| 5/8-16 (Radius Rod Clamp Bolt).....   | 130 lb-ft    170 lb-ft |
| 5/8-18 (Spring Retainer Bolt).....  | 35 lb-ft     50 lb-ft  |
|  Hutchens Industries, Inc., P.O. Box 1427, Springfield, Missouri 65801-1427 Toll Free 1 (800) 654-8824   |                        |

## REYCO 21B SPRING RIDE SUSPENSION

| <b>TORQUE REQUIREMENTS</b>  |            |            |
|---|------------|------------|
| <b>(cast hangers)</b>   |            |            |
| 1. Tighten 3/4" or 7/8" U-bolt nuts                                 | 300-325 FP | 410-440 Nm |
| 2. Tighten 1" torque arm end nuts                                   | 140-160 FP | 190-220 Nm |
| 3. Tighten 5/8" torque arm clamp nuts                               | 125-150 FP | 170-205 Nm |
| 4. Tighten 1" equalizer capscrews                                   | 400-450 FP | 540-610 Nm |
| 5. Tighten 1/2" spring retainer nuts                                | 70-80 FP   | 95-110 Nm  |
| <b>(fab hangers)</b>  |            |            |
| 1. Tighten 3/4" or 7/8" U-bolt nuts—steel springs                   | 300-325 FP | 410-440 Nm |
| 2. Tighten 3/4" or 7/8" U-bolt nuts (composite springs)             | 250 FP     | 340 Nm     |
| 3. Tighten 11/4" equalizer shaft fastener nuts                      | 575-625 FP | 780-850 Nm |
| 4. Tighten 21/2" equalizer shaft fastener nuts m (FWWB 54"-65 1/2") | 300-325 FP | 410-440 Nm |
| 5. Tighten 11/2" equalizer shaft fastener nuts (FWWB 72"-109")      | 200-225 FP | 270-305 Nm |
| 6. Tighten 1" torque arm bolt nuts                                  | 140-160 FP | 190-220 Nm |
| 7. Tighten 5/8" torque arm clamp nuts                               | 125-150 FP | 170-200 Nm |
| 8. Tighten 3/4" torque arm clamp nuts                               | 175-200 FP | 240-270 Nm |
| 9. Tighten 1/2" spring retainer nuts                                | 70-80 FP   | 95-110 Nm  |
| ft lb = Foot - Pounds; Nm = Newton - Meters                         |            |            |

5.2.12.2 MECHANICAL SUSPENSION (cont'd)

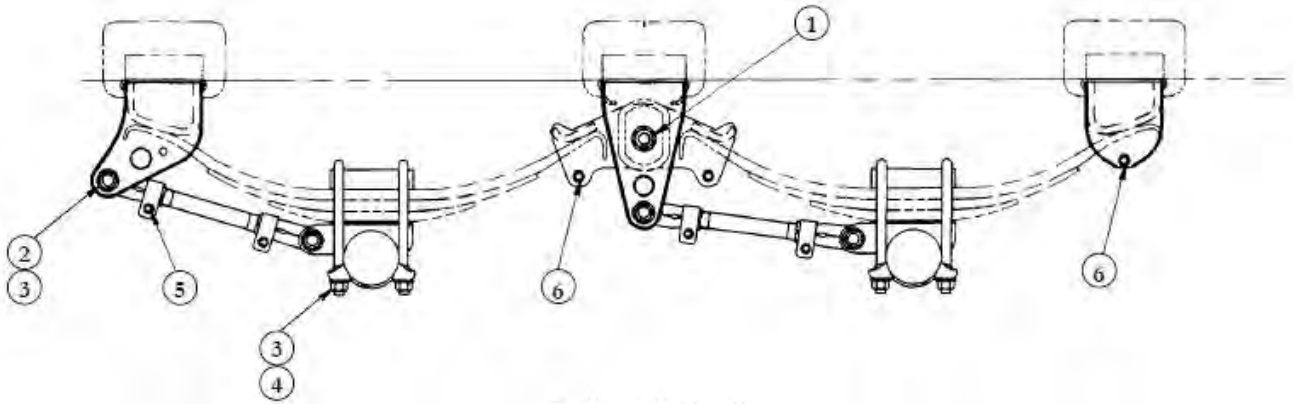

Tandem Axle Overslung

HUTCH SUSPENSION SYSTEM

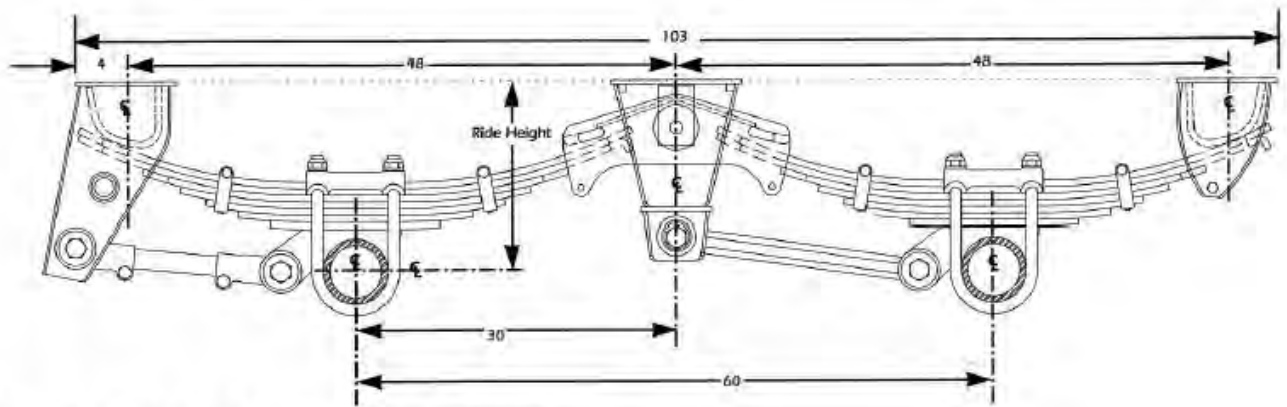

REYCO 21B SUSPENSION SYSTEM

## 5.2.13 AIR SYSTEM

Trailers are equipped with an air system, that is pressurized by a compressor on the tractor, for operating the discharge gates, brakes and air suspension (if so equipped). All components must be in good condition for the system to function and perform as intended. The air system must be inspected to be kept in good condition and functional checks performed to be sure it is operating as required.

### 5.2.13.1 AIR SYSTEM INSPECTION

The pre-trip or pre-start inspection include several air system related checks, inspections or tasks including but not limited to:

#### Daily

1. Check that the glad hands are clean and in good condition. Check seals in glad hand Clean, repair or replace as required.
2. Check that the air hoses between the tractor and the trailer are routed to prevent rubbing, chaffing or pinching. Reroute to correct condition if required.
3. Drain moisture from all air tanks. Pull on the cable attached to drain valve on the bottom of each tank until the water or spray no longer can be seen.
4. Check that all the lines and hoses conveying air along the frame are tied up and secured to prevent dragging, scuffing or snagging. Tie up or protect as required to correct the condition. Damaging an air system component can cause a sudden loss of pressure and result in a loss of service brakes.

#### IMPORTANT

Tanks must be drained daily in high humidity and cold temperature conditions to prevent getting water or ice in the system. During cold weather operation use only recommended air line anti freeze in the trailer air system. Alcohol or methyl hydrate is not to be used because they will remove vital lubricants causing premature failures of valves and components. Traces of these products will void any warranty consideration.

5. Drain the water from the bottom of the filter cannister in the discharge gate air system.

#### IMPORTANT

New FMVSS-121 regulations mandate higher pressures in the supply line to insure proper brake operation. Set the compressor pressure for cut-in to 105 psi and cut-out to 120 psi. Do not use additives in the air systems.

## 5.2.13.2 AIR SYSTEM FUNCTION

A vehicle air system is a combination of the components on the tractor and the trailer. All must be maintained in good condition for the entire system to function as required. Although a visual check will indicate the outer condition of the components, it does not indicate the leaks or responsiveness of the system. To evaluate the integrity and responsiveness of the system, perform these functional checks:

1. Attach the trailer to a tractor and connect all the air and electrical lines.
2. Block wheels.
3. Stop tractor engine and exhaust air from all tanks.
4. Start engine and run at fast idle (1200-1500 RPM) to charge the air system.

#### Verify that:

- a. Low pressure alarm goes off when the system pressure drops below 50 psi.
- b. Increasing the system pressure between 50 psi and 80 psi takes less than 3 minutes.
- c. The compressor cuts out when the system pressure exceeds 120 psi.
- d. Fan brakes to use air. Compressor must engage when system pressure drops below 105 psi.

#### NOTE

Release spring brakes before fanning service brakes.

5. Push emergency valve to charge trailer system. Apply and release service brakes.
6. Build system above 120 psi and stop engine.

#### Verify that:

- a. Main tank pressure does not drop more than 18 psi when brakes are fully applied using brake pedal. If pressure drop exceeds 18 psi, adjust brakes and recheck.
- b. System pressure should not drop more than 4 psi per minute. Listen for audible leaks.
- c. Release foot valve, fan treadle to drop main reservoir pressure. Brakes should dynamite automatically when the pressure drops below 60 psi.

Adjust or repair system until these conditions are met.



## 5.2.14 ELECTRICAL SYSTEM

All trailers are equipped with an electrical system for providing power for lights and electrical controls. All components are designed to minimize the effects of foul weather and adverse operating conditions. However, it is the responsibility of the operator to check and verify that all components are in good condition and functioning as intended.

During the daily or pre-trip inspection, always verify that each light functions as required. It may be helpful to work with another individual to verify the function of the brake or turn signal lights. A properly functioning electrical system is the only way an operator can communicate his intentions to other drivers. Checking the electrical system includes but is not limited to:

1. Replace any bulb that is burned out.
2. Clean all reflective lenses. Replace any that are cracked or broken.
3. Clean all connections and terminals to a light that is flickering.
4. Reroute and secure any wires or cables that are dangling or have snagged on something.
5. Check the integrity of the seal around each light. Replace any seal that is cracked or damaged.
6. Annually (or more often as necessary) check and re-seal all connectors with a non-conductive grease.

**Table 11 Trailer Light Requirements**

| Function     | P/N | Size (Watts) |
|--------------|-----|--------------|
| 4" Tail Lamp |     | 8            |
| Signal/Brake |     | 27           |
| Side Signal  |     | 27           |
| Clearance    |     | 8            |
| Marker       |     | 5            |



**Electrical Connectors**



**Side Signal**



**Rear**

**Fig. 77 LIGHTING**

## 5.2.15 DISCHARGE GATE

CUL discharge gates are equipped with stops for controlling the opening width when unloading. Place the stop in the required position and secure with the anchor pin and retainer.

Clam discharge gate is equipped with stops on both ends to prevent twisting during opening or closing. Always place the stops in the same position on each end of the gate.



**Clam Gates**



**CUL Gates**

**Fig. 78 OPENING STOPS**



## 5.2.16 OILER (ON TRAILERS EQUIPPED WITH STEEL AIR CYLINDERS)

The discharge gate air control system is equipped with an oiler to supply a light mist of oil into the air supply as it flows to the cylinder. The oil mist lubricates all the internal components as the cylinder opens and closes the discharge gates.

Remove the fill plug on the top of the mounting head and add oil through this hole. This system allows oil to be added even if the system is pressurized. Do not overfill. Install plug when filled and tighten to its specified torque.

### 1. Oiler:

Oiler is preset at the factory, but may have to be reset after first use. The valve and cylinder need 4-8 drops of oil per cycle. While opening the gates look into inspection glass (A) and count the drops. If more oil is required turn screw (B) counter clockwise, clockwise for less oil. **INSUFFICIENT OIL WILL DAMAGE THE CYLINDER SEALS AND CAUSE POOR GATE PERFORMANCE. EXCESSIVE OIL WILL TEND TO FLOOD THE VALVE AND CAUSE ERRATIC VALVE FUNCTIONS.**

### 2. Adding Oil:

Oil levels in the Oiler should be inspected daily. Also periodically check the amount of drops in the inspection glass (A). To add oil remove plastic cap (C) and fill reservoir as shown. This system allows oil to be added even if system is pressurized. Install plug when filled and tighten.



Clam

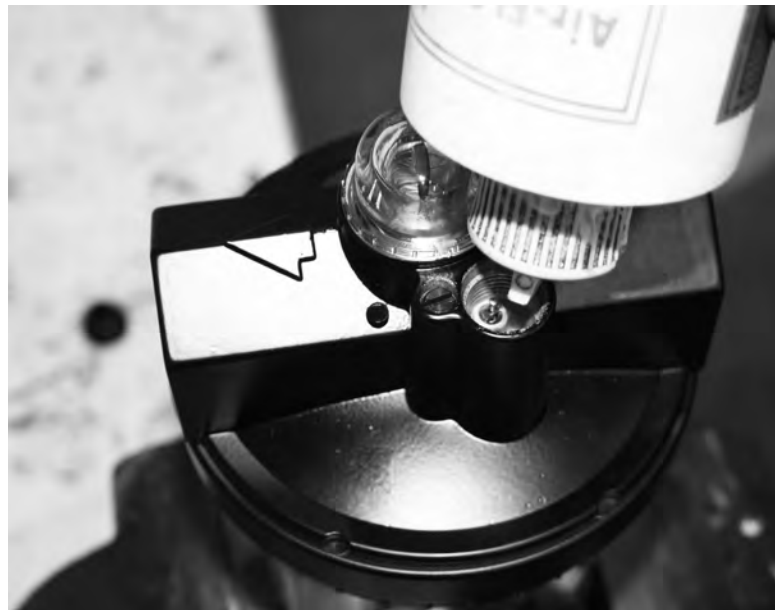

Clam

Fig. 79 OILER

**NOTE: Composite cylinders do not require oilers.**

## 6 TROUBLE SHOOTING

The Midland Gravel Trailer uses a clam or cross discharge gate for unloading material as required. It is a simple and reliable system that requires minimal maintenance.

In the following section, we have listed problems, causes and solutions to the problems that you may encounter.

If you encounter a problem that is difficult to solve, even after having read through this trouble shooting section, and through the specifically related components manufacturer's manuals, please call your local Midland dealer or distributor. Before you call, please have this Operator's Manual and the serial number from your trailer ready.

### PROBLEM

### CAUSE

### SOLUTION

Trailer "Dog-Tracks"...

Trailer out of alignment.

Realign per procedure provided by the suspension manufacturer.

---

## PROBLEM

## CAUSE

## SOLUTION

### Tires

|                            |   |   |
|----------------------------|---|---|
| High or uneven tire wear.  | Over or under inflation.                      | Inflate to proper pressure.                 |
|                            | Loose wheel stud nuts or clamps.              | Tighten wheel stud nuts or clamps.          |
|                            | Loose or tight wheel bearing.                 | Adjust bearings.                            |
|                            | Axle bent or out of alignment.                | Straighten, align or replace axle.          |
|                            | Tires not properly matched.                   | Match tires.                                |
|                            | Improper acting brakes.                       | Correct brakes as required.                 |
|                            | Rapid stopping.                               | Apply brakes slowly when approaching stops. |
|                            | High speed.                                   | Reduce speed.                               |
| <hr/>                      |   |   |
| Scuffed tires.             | Over or under inflation.                      | Inflate to proper pressure.                 |
|                            | Excessive speed on turns.                     | Reduce speed.                               |
| Wobbly tires.              | Tire wobble due to uneven rim clamping.       | Torque tighten all rim clamps.              |
|                            | Worn or damaged wheel bearings.               | Replace bearings.                           |
|                            | Bent wheel or rim.                            | Replace wheel or rim.                       |
|                            | Bent axle.                                    | Replace or straighten axle.                 |
| <hr/>                      |   |   |
| Dog tracking.              | Leaf spring broken.                           | Replace leaf or complete spring.            |
|                            | Bent axle.                                    | Replace or straighten axle.                 |
|                            | Frame or suspension (axles) out of alignment. | Straighten frame or align axles.            |
| <hr/>                      |   |   |
| Loss of tire air pressure. | Puncture in tire.                             | Repair or replace tire.                     |
|                            | Faulty valve or valve core.                   | Replace valve assembly or core.             |
|                            | Wheel or rim damage.                          | Replace wheel or rim.                       |

**PROBLEM****CAUSE****SOLUTION****Electrical**

Lights flicker or do not come on.

Bad connection.

Check electrical system circuits.

Frayed wires.

Repair as required.

Battery on tractor not sufficiently charged.

Charge battery.

Damaged or disconnected wire on ground cable.

Repair or replace cable.

Poor ground at sockets.

Repair as necessary.

---

Complete loss of trailer lights.

Broken main harness.

Repair or replace.

Junction box failure.

Replace junction box.

Frayed wires.

Repair as required.

Damaged or disconnected ground cable.

Repair or replace cable as required.

Loose or corroded connection in ground lead between tractor and trailer.

Repair or replace.

---

Lights flash improperly or appear to be crossed.

Internal short in junction box.

Replace junction box.

## PROBLEM

## CAUSE

## SOLUTION

### Air System

Excessive compressor cycling.

Air leak.

Check air line fittings and hose connections on service or supply line.

Check service chamber at clamp housing, push rod for damage.

Check service chamber diaphragm.

Check emergency chamber clamp and vent holes for leakage.

Repair or replace air chamber as required.

Check FFVII brake valve. Repair or replace as required.

---

Trailer brakes slow and sluggish.

System or component failure.

Check slack adjuster and chamber/spring brake push rod alignment for interference.

Assure slack adjuster and chamber/spring brake push rod angle 90° applied with proper adjustment.

Assure open lines - no kinks, bends, closed shut-off cocks, restrictions, excessive elbows.

Assure adequate tractor brake function.

Have authorized service center check for adequate pressure and timing balance relative to tractor/trailer application.

---

## PROBLEM

## CAUSE

## SOLUTION

### Air System (cont'd)

Trailer brakes drag.

System or component failure

Assure emergency line exceeds 120 psi pressure; check and maintain governor at max. cut-in.

Check slack adjuster and chamber/spring brake push rod alignment for interference.

Assure slack adjuster and chamber/spring brake push rod angle 90° applied with proper adjustment.

Assure open lines - no kinks, bends, closed shut-off cocks, restrictions, excessive elbows.

Check for trapped service air pressure at trailer service/delivery hoses. If air pressure is noted, check for full release of all application valves (tractor/truck/trailer).

---

Trailer brakes won't apply (service).

System or component failure.

Check air delivery to emergency system.

Check air delivery to service gladhand.

Check air delivery to air chamber or spring brake.

Check air delivery to all reservoirs at system working pressure.

Check slack adjuster and chamber/spring brake push rod alignment for interference.

Check slack adjuster and chamber/spring brake push rod angle 90° applied with proper adjustment.

---

Park/emergency brakes won't release.

System or component failure.

Check air jumper hoses are not crossed between tractor and trailer.

Check air delivery to emergency gladhands exceeds 120 psi.

Check air delivery to FFV valve.

Check air delivery to all reservoirs at system working pressure.



## PROBLEM

## CAUSE

## SOLUTION

### Air System (cont'd)

Park/emergency brakes won't release (cont'd).

System or component failure (cont'd).

Check open lines - no kinks, bends, closed shut-off cocks, restrictions, excessive elbows.

Check that brake shoes are not frozen to drums.

---

Park/emergency brakes won't hold.

System or component failure.

Check slack adjuster and chamber/spring brake push rod alignment for interference.

Assure slack adjuster and chamber/spring brake push rod angle 90° applied with proper adjustment.

---

Air reservoir leaks or loose mounting.

System or component failure.

Replace/use rubber grommets with integral brackets.

---

Semi-trailer "Runs-Up" on tractor.

Check brake linkage.

Assure slack adjuster and chamber/spring brake push rod angle 90° applied with proper adjustment.

Check gladhand connection.

Assure open lines - no kinks, bends, closed shut-off cocks, restrictions, excessive elbows.

Have authorized service center check for adequate pressure and timing balance relative to tractor/trailer application.

---

Poor braking performance.

Uneven brakes.

Check slack adjuster and chamber/spring brake push rod angle 90° applied with proper adjustment.

Check slack adjuster and chamber/spring brake push rod angle 90° applied with proper adjustment.

Check open lines - no kinks, bends, closed shut-off cocks, restrictions, excessive elbows.

Check a leak free system by applying service brake and inspecting.

## PROBLEM

## CAUSE

## SOLUTION

### Air System (cont'd)

Poor braking performance (cont'd).

Trailer brake lining wear excessive.

Have authorized service center check for adequate pressure and timing balance relative to tractor/trailer application.

Proceed per problem "trailer brakes drag."

Trailer brakes slow to apply.

Check slack adjuster and chamber/spring brake push rod angle 90° applied with proper adjustment.

Check air delivery to all reservoirs at system working pressure.

Check open lines - no kinks, bends, closed shut-off cocks, restrictions, excessive elbows.

Have authorized use of "jumper hose analyser" and duplex gauge to pin-point brake imbalance.

Check functional return spring in service chamber or spring brake.

Check open lines - no kinks, bends, closed shut-off cocks, restrictions, excessive elbows.

Trailer service brakes slow to release.

Have authorized use of "jumper hose analyser" and duplex gauge to pin-point brake imbalance.

Slack adjuster not auto-adjusting.

Check for damaged actuator rod. Replace as required.

Slack adjuster internal components seized. Replace.

Cracked housing.

Replace slack adjuster.

Worn clevis pin bushing.

Replace bushing

## PROBLEM

## CAUSE

## SOLUTION

### Air System (cont'd)

Poor braking performance (cont'd).

Full function valve (FFV) leaks at exhaust port with all brakes released.

Replace FFV valve.

Full function valve (FFV) leaks at exhaust port with service brakes applied.

Replace FFV valve.

Spring parking brake (service only service chamber side of spring brake) drags or won't release.

Check for:

- Improper adjustment, restriction or broken line.
- Diaphragm failure.
- System pressure too low (120 psi min).
- Improper manual release.
- Broken return spring (spring side).
- Broken power spring.
- Replace entire unit or piggy-back emergency section.

Spring parking brake (service only service chamber side of spring brake) leaks when pressurized for park brake release.

Check for:

- Ruptured spring side diaphragm.
- Hose leaks.

# 7 SPECIFICATIONS

## 7.1 BOLT TORQUE

### CHECKING BOLT TORQUE

The tables shown below give correct torque values for various bolts and capscrews. Tighten all bolts to the torques specified in chart unless otherwise noted. Check tightness of bolts periodically, using bolt torque chart as a guide. Replace hardware with the same strength bolt.

### ENGLISH TORQUE SPECIFICATIONS

| Bolt Diameter "A" | Bolt Torque*           |     |                        |     |                        |     |
|-------------------|------------------------|-----|------------------------|-----|------------------------|-----|
|                   | SAE 2<br>(N.m) (lb-ft) |     | SAE 5<br>(N.m) (lb-ft) |     | SAE 8<br>(N.m) (lb-ft) |     |
| 1/4"              | 8                      | 6   | 12                     | 9   | 17                     | 12  |
| 5/16"             | 13                     | 10  | 25                     | 19  | 36                     | 27  |
| 3/8"              | 27                     | 20  | 45                     | 33  | 63                     | 45  |
| 7/16"             | 41                     | 30  | 72                     | 53  | 100                    | 75  |
| 1/2"              | 61                     | 45  | 110                    | 80  | 155                    | 115 |
| 9/16"             | 95                     | 60  | 155                    | 115 | 220                    | 165 |
| 5/8"              | 128                    | 95  | 215                    | 160 | 305                    | 220 |
| 3/4"              | 225                    | 165 | 390                    | 290 | 540                    | 400 |
| 7/8"              | 230                    | 170 | 570                    | 420 | 880                    | 650 |
| 1"                | 345                    | 225 | 850                    | 630 | 1320                   | 970 |

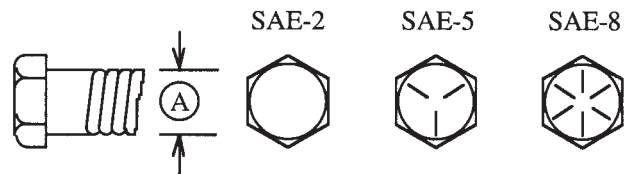

### METRIC TORQUE SPECIFICATIONS

| Bolt Diameter "A" | Bolt Torque*         |      |                       |      |
|-------------------|----------------------|------|-----------------------|------|
|                   | 8.8<br>(N.m) (lb-ft) |      | 10.9<br>(N.m) (lb-ft) |      |
| M3                | .5                   | .4   | 1.8                   | 1.3  |
| M4                | 3                    | 2.2  | 4.5                   | 3.3  |
| M5                | 6                    | 4    | 9                     | 7    |
| M6                | 10                   | 7    | 15                    | 11   |
| M8                | 25                   | 18   | 35                    | 26   |
| M10               | 50                   | 37   | 70                    | 52   |
| M12               | 90                   | 66   | 125                   | 92   |
| M14               | 140                  | 103  | 200                   | 148  |
| M16               | 225                  | 166  | 310                   | 229  |
| M20               | 435                  | 321  | 610                   | 450  |
| M24               | 750                  | 553  | 1050                  | 774  |
| M30               | 1495                 | 1103 | 2100                  | 1550 |
| M36               | 2600                 | 1917 | 3675                  | 2710 |

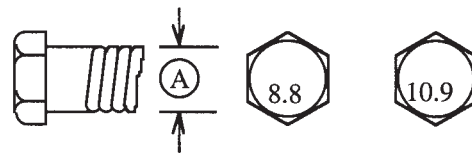

Torque figures indicated above are valid for non-greased or non-oiled threads and heads unless otherwise specified. Therefore, do not grease or oil bolts or capscrews unless otherwise specified in this manual. When using locking elements, increase torque values by 5%.

\* Torque value for bolts and capscrews are identified by their head markings.

# 8 INDEX

| <b>I</b>                           | <b>PAGE</b> |
|------------------------------------|-------------|
| Introduction .....                 | 1           |
| <br><b>O</b>                       |             |
| Operation Guidelines.....          | 11          |
| Air System .....                   | 28          |
| Cylinders .....                    | 30          |
| Filter and Oiler .....             | 28          |
| Tanks .....                        | 29          |
| Break-In.....                      | 13          |
| Controls.....                      | 15          |
| Discharge Gates.....               | 26          |
| Clam Shell Discharge Gate .....    | 26          |
| Close Under Load (CUL) Gates.....  | 27          |
| Hooking Up/Unhooking.....          | 23          |
| Hooking Up .....                   | 23          |
| Unhooking .....                    | 25          |
| Loading/Unloading.....             | 31          |
| Loading .....                      | 31          |
| Unloading .....                    | 32          |
| Optional Equipment.....            | 36          |
| Pre-Operation Vehicle Inspection   |             |
| Procedure.....                     | 20          |
| Terminology .....                  | 12          |
| To the New Operator or Owner ..... | 11          |
| Transporting .....                 | 32          |
| Braking Guidelines .....           | 34          |
| Operating Instructions.....        | 33          |
| Tires.....                         | 35          |

| <b>S</b>                                | <b>PAGE</b> |
|---|-------------|
| Safety .....                            | 2           |
| General Safety.....                     | 3           |
| Loading Safety .....                    | 5           |
| Maintenance Safety.....                 | 4           |
| Operating Safety .....                  | 4           |
| Safety Signs .....                      | 5           |
| Sign-Off Form.....                      | 6           |
| Tire Safety .....                       | 5           |
| Travel Safety.....                      | 5           |
| Safety Sign Locations .....             | 7           |
| Service and Maintenance.....            | 39          |
| Periodic Maintenance and Adjustments .. | 53          |
| Air Chamber/Spring Brake .....          | 78          |
| Air System .....                        | 85          |
| Air System Function.....                | 85          |
| Air System Inspection .....             | 85          |
| Axle Alignment .....                    | 57          |
| Brakes .....                            | 67          |
| Discharge Gate.....                     | 87          |
| Electrical System.....                  | 86          |
| Fifth Wheel .....                       | 56          |
| Kingpin and Oscillating Fifth Wheel     |             |
| Plate .....                             | 55          |
| Oiler.....                              | 88          |
| Slack Adjusters .....                   | 71          |
| Suspension System.....                  | 79          |
| Air Ride Suspension.....                | 79          |
| Mechanical Suspension.....              | 83          |
| Tires.....                              | 65          |
| Torque Specification Summary .....      | 53          |
| Trailer ABS.....                        | 77          |
| Wheels.....                             | 63          |
| Wheel Hubs/Bearings.....                | 59          |
| Service.....                            | 39          |
| Fluids and Lubricants.....              | 39          |
| Greasing .....                          | 39          |
| Service Record Summary (Lube).....      | 52          |
| Servicing Intervals .....               | 40          |
| Specifications.....                     | 97          |
| Bolt Torque .....                       | 97          |

## **T**

|                        |    |
|------------------------|----|
| Trouble Shooting ..... | 89 |
|------------------------|----|